



Installation, Service & Maintenance Manual

for models

BL, NL, SL, TL, CL
105A, 105B, 105C, 105D, 105E, 105F, 105G

SAFETY PRECAUTIONS

Before operating the generating set, read the generating set operation manual and this generator manual and become familiar with it and the equipment.

SAFE AND EFFICIENT OPERATION CAN ONLY BE ACHIEVED IF THE EQUIPMENT IS CORRECTLY OPERATED AND MAINTAINED.

Many accidents occur because of failure to follow fundamental rules and precautions.

ELECTRICAL SHOCK CAN CAUSE SEVERE PERSONAL INJURY OR DEATH.

- Ensure installation meets all applicable safety and local electrical codes. Have all installations performed by a qualified electrician.
- Do not operate the generator with protective covers, access covers or terminal box covers removed.
- Disable engine starting circuits before carrying out maintenance.
- Disable closing circuits and/or place warning notices on any circuit breakers normally used for connection to the mains or other generators, to avoid accidental closure.

Observe all **IMPORTANT, CAUTION, WARNING, and DANGER** notices, defined as:

Important ! Important refers to hazard or unsafe method or practice which can result in product damage or related equipment damage.

Caution ! Caution refers to hazard or unsafe method or practice which can result in product damage or personal injury.



Warning !

Warning refers to a hazard or unsafe method or practice which **CAN** result in severe personal injury or possible death.



Danger !

Danger refers to immediate hazards which **WILL** result in severe personal injury or death.

Due to our policy of continuous improvement, details in this manual which were correct at time of printing, may now be due for amendment. Information included must therefore not be regarded as binding.

FOREWORD

The function of this book is to provide the user of the Markon generator with an understanding of the principles of operation, the criteria for which the generator has been designed, and the installation and maintenance procedures.

Each generator has been so designed, constructed, tested and examined as to ensure that it will be safe and without risk to health when properly used. Machine outputs etc. are shown on the nameplate attached to the frame.

Specific areas where the lack of care or use of incorrect procedures could lead to equipment damage and/or personal injury are highlighted, with **IMPORTANT, CAUTION, WARNING and/or DANGER** notes, and it is **IMPORTANT** that the contents of this book are read and understood before proceeding to fit or use the generator.

Any persons carrying out operating and maintenance procedures should wear any appropriate protective clothing and equipment, use the correct tools and observe any regulations contained in, or made pursuant, to the Health and Safety at Work Act 1974 or any other relevant statute.

The Service, Sales and technical staff of Markon are always ready to assist and reference to the company for advice is welcomed.

EC DECLARATION OF INCORPORATION

All Markon generators are supplied with a declaration of incorporation for the relevant EC legislation, typically in the form of a label as below.

Under the EC Machinery Directive section 1.7.4. It is the responsibility of the generator set builder to ensure the generator serial and identity numbers are clearly displayed in the space provided inside the back cover of this book.

○
EC DECLARATION OF INCORPORATION
<small>IN ACCORDANCE WITH THE SUPPLY OF MACHINERY (SAFETY) REGULATIONS 1992 AND THE SUPPLY OF MACHINERY (SAFETY) (AMENDMENT) REGULATIONS 1994 IMPLEMENTING THE EC MACHINERY DIRECTIVE 89/392/EEC AS AMENDED BY 91/368/EEC.</small>
<small>THIS STAMFORD A.C GENERATOR WAS MANUFACTURED BY OR ON BEHALF OF NEWAGE INTERNATIONAL LTD BARNACK ROAD STAMFORD LINCOLNSHIRE ENGLAND</small>
<small>THIS COMPONENT MACHINERY MUST NOT BE PUT INTO SERVICE UNTIL THE MACHINERY INTO WHICH IT IS TO BE INCORPORATED HAS BEEN DECLARED IN CONFORMITY WITH THE PROVISIONS OF THE SUPPLY OF MACHINERY (SAFETY) REGULATIONS 1992/MACHINERY DIRECTIVE.</small>
<small>FOR AND ON BEHALF OF NEWAGE INTERNATIONAL LIMITED</small>
<small>NAME: LAWRENCE HAYDOCK POSITION: TECHNICAL DIRECTOR</small>
<small>SIGNATURE:</small>
<small>THIS COMPONENT MACHINERY CARRIES THE CE MARK FOR COMPLIANCE WITH THE STATUTORY REQUIREMENTS FOR THE IMPLEMENTATION OF THE FOLLOWING DIRECTIVES The EMC Directive 89/368/EEC</small>
<small>WARNING! This Component Machinery shall not be used in the Residential, Commercial and Light Industrial environment unless it also conforms to the relevant standard (EN 50081 - 1) REFER TO FACTORY FOR DETAILS</small>
<small>ii) The Low Voltage Directive 73/23/EEC as amended by 93/68/EEC</small>



Markon generators are manufactured to Q.A. procedures conforming to BS EN ISO 9002.

ELECTROMAGNETIC COMPATIBILITY

Additional Information

European Union

Council Directive 89/336/EEC

For installations within the European Union, electrical products must meet the requirements of the above directive, and Markon ac generators are supplied on the basis that:

- They are to be used for power-generation or related function.
- They are to be applied in one of the following environments:
 - Portable (open construction - temporary site supply)
 - Portable (enclosed - temporary site supply)
 - Containerised (temporary or permanent site supply)
 - Ship-borne below decks (marine auxiliary power)
 - Commercial vehicle (road transport / refrigeration etc)
 - Rail transport (auxiliary power)
 - Industrial vehicle (earthmoving, cranes etc)
 - Fixed installation (industrial - factory / process plant)
 - Fixed installation (residential, commercial and light industrial - home / office / health)
 - Energy management (Combined heat and power and/or peak lopping)
 - Alternative energy schemes
- The standard generators are designed to meet the 'industrial' emissions and immunity standards. Where the generating set is required to meet the residential, commercial and light industrial emissions and immunity standards then reference should be made to the factory.
- The installation earthing scheme involves connection of the generator frame to the site protective earth conductor using a minimum practical lead length.
- Maintenance and servicing with anything other than factory supplied or authorised parts will invalidate any Newage liability for EMC compliance.

CONTENTS

SECTION 1	INTRODUCTION	5
1.1	BL105 Generator	5
1.2	NL105 Generator	6
1.3	SL105 Generator	7
1.4	TL105 Generator	8
1.5	CL105 Generator	9
SECTION 2	APPLICATION	10
2.1	Standards	10
2.2	Airflow	10
2.3	Direction Of Rotation	10
2.4	Drive Arrangement	10
2.4.1	Road Vehicle Generators	10
2.5	Bearings	11
2.5.1	Road Vehicle Generators	11
2.6	Earthing	11
2.7	Loading	11
SECTION 3	INSTALLATION	12
3.1	Safety Warnings	12
3.2	Inspection	12
3.3	Coupling to Engine	12
3.4	Electrical Connections	12
3.5	Voltage Selection	14
3.6	Voltage Adjustment For The SL105 - AVR MD1C	15
SECTION 4	SERVICE & MAINTENANCE	17
4.1	General	17
4.2	Insulation Resistance Check	18
4.3	Fault Finding	18
4.4	Residual Voltage/Field Flashing	24
4.4.1	Linear Reactor Check	25
4.4.2	Current Transformer Check	25
4.5	Resistance Charts	26
SECTION 5	ASSEMBLY/DISMANTLING PROCEDURE	28
5.1	Assembling Generator To Engine	28
5.2	Dismantling Stator Frame Assembly	29
5.3	Withdrawing Rotor From Engine	29
5.4	Removal/Replacement Of Capacitor - BL Models	29

CONTENTS

5.5	Removal/Replacement Of Diode Varistor Assembly - BL Models	29
5.6	Removal/Replacement Of AVR - SL Models	30
5.7	Removal/Replacement Of AVR - TL Models	30
5.8	Removal/Replacement Of Diode Bridge - SL and NL Models	30
5.9	Removal/Replacement Of Choke - SL and NL Models	31
5.10	Removal/Replacement Of Radio Interference Suppressor (RIS) -SL and TL Models	31
5.11	Removal/Replacement Of Bearing	31
5.12	Removal/Replacement Of Brushes/Brush Calliper Assembly - CL Models	32
5.13	Removal/Replacement Of Brushes/Brushbox Assembly - SL, TL, & NL Models	32
5.14	Torque Settings	32
SECTION 6	SPARES AND AFTER SALES SERVICE	33
6.1	Recommended Spares	33
6.2	After Sales Service	34
	BL105 Parts Identification - Single Bearing	35
	Typical BL105 Generator - Single Bearing	36
	NL105 Parts Identification	37
	Typical NL105 Generator	38
	SL105 Parts Identification	39
	Typical SL105 Generator	40
	BL105 Parts Identification - Two Bearing	41
	Typical BL105 Generator - Two Bearing	42
	TL105 Parts Identification	43
	Typical TL105 Generator	44
	CL105 Parts Identification	45
	Typical CL105 Generator	46

Warranty Details Inside Backcover

SECTION 1

INTRODUCTION

Models covered by this manual are designated as follows:-

BL105A	NL105E	SL105A	TL105E	CL105G
BL105B	NL105F	SL105B	TL105F	
BL105C	NL105G	SL105C	TL105G	
BL105D		SL105D		
BL105E		SL105E		
BL105F		SL105F		
BL105G		SL105G		

1.1 BL105 GENERATOR

The BL105 is a self exciting brushless generator, designed to operate with single phase loads at or near a power factor of 1.0. The principle of operation is schematically represented in the diagram below. The auxiliary winding, in conjunction with the excitation capacitor, provides excitation by inducing current in the rotor (field) windings which is rectified to produce a direct current field. The main stator winding is designed for series/parallel connection to give a dual voltage output and no voltage adjustment is possible.

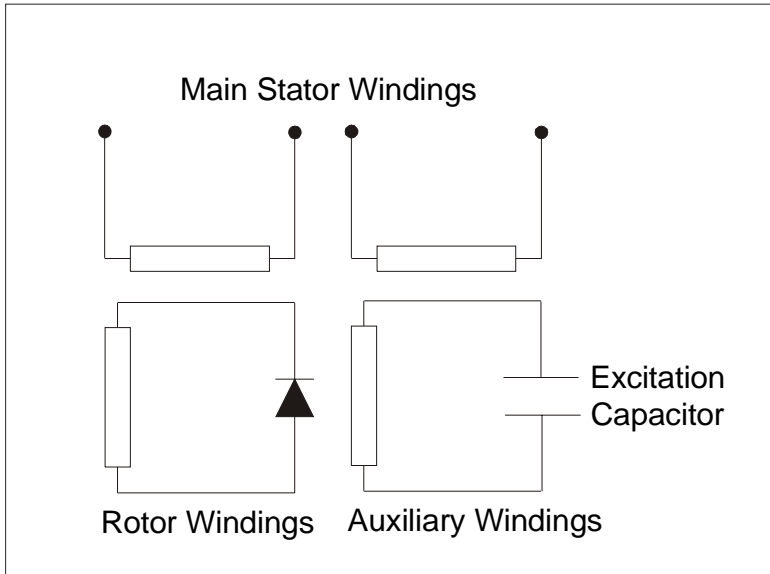

1.2 NL105 GENERATOR

The NL 105 generator is of self-exciting rotating field design.

The principle of operation is schematically represented in the diagram below. The auxiliary winding provides excitation power through a choke and rectifier into the rotating field via sliprings.

The main stator winding is designed for series/parallel connection to give a dual voltage output primarily designed for unity power factor loads.

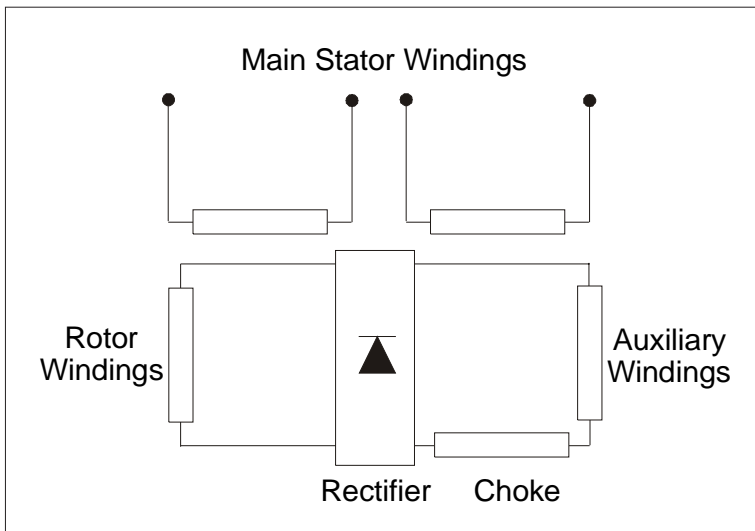

Some NL 105 generators are supplied with a d.c. auxiliary output winding and are schematically represented in the diagram below.

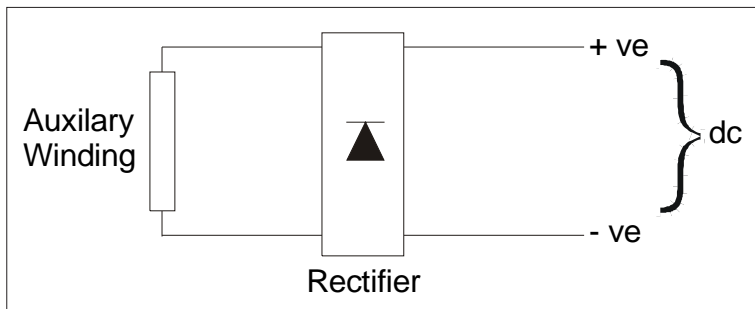

1.3 SL105 GENERATOR

The SL105 generator is of self-exciting, automatic voltage regulator (AVR) controlled, rotating field design. It is designed to operate with close regulation when supplying single phase loads. Primarily designed for loads at or near unity power factor, it has a capability of operation at 0.8 power factor.

The principle of operation is schematically represented in the diagram below. The auxiliary winding provides excitation power through a choke and rectifier into the rotating field via sliprings.

The AVR diverts excess excitation at low loads to maintain the main stator winding output voltage within close limits.

The main stator winding is designed for series/parallel connection to give a dual voltage output with voltage adjustment.

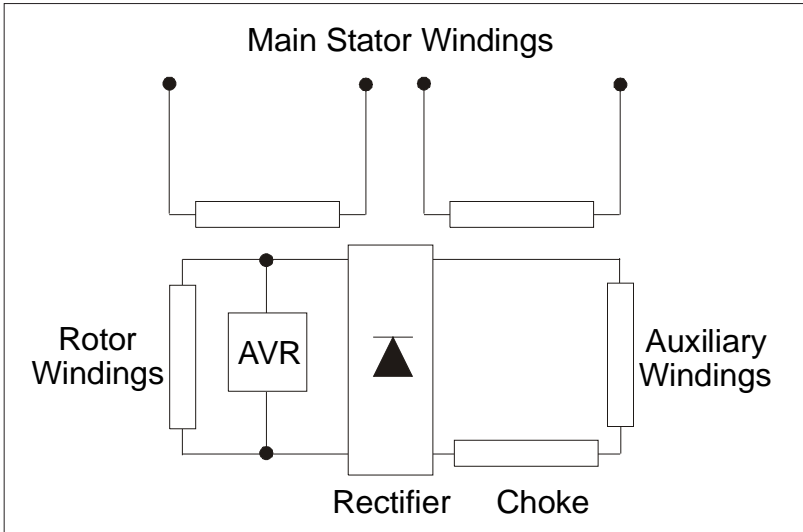

The SL105 generator may be supplied without a divertor AVR for specific applications. For these generators the instructions given in this manual for the SL105 generator apply, but references to the AVR or its control should be ignored.

1.4 TL105 GENERATOR

The TL105 is a self-exciting, automatic voltage regulator (AVR) controlled rotating field three phase generator. It is designed to operate with close voltage regulation when supplying balanced and unbalanced loads at power factors between 0.8 and 1.0.

The principle of operation is schematically represented in the block diagram below.

The aux stator winding provides excitation power through the AVR which controls the level of excitation passed via the sliprings into the field winding (rotor).

The AVR senses the voltage output of the main stator winding and controls the excitation at varying loads to maintain the main stator winding output voltage within close limits.

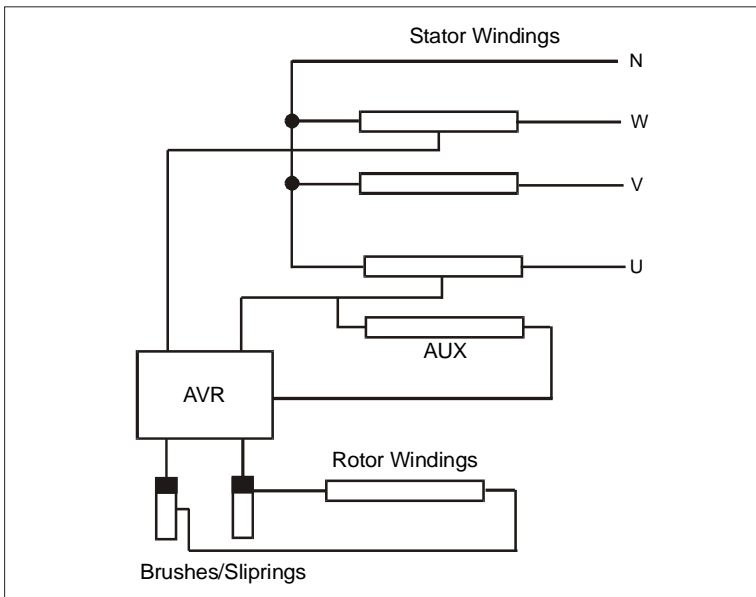

Note: AVR tapping point varies depending upon generator output voltage, the AVR input voltage must be in the range of 100 - 120v.

1.5 CL105 GENERATOR

The CL105 is a self-exciting three phase generator having current compounded excitation control. It is specifically designed for use in vehicle refrigeration equipment and is capable of operation over a wide speed range, i.e. 1800 to 3600 r.p.m., delivering an output voltage of 250 to 500 volts at frequencies of 30 to 60 Hz respectively.

The excitation control, which may be generator mounted or remote, consists of a linear reactor (LR) providing the no-load excitation component, and a current transformer (CT) providing the increased excitation required when the generator is loaded.

It is the frequency sensitive nature of the LR and CT that enables virtually proportional control of output voltage with respect to speed (or Hz).

The principle of operation is schematically represented below.

The elements of excitation power derived from the LR and CT are vectorially summed, rectified and fed via sliprings into the main field (rotor) winding, such that the generator output voltage is maintained within limits with varying load.

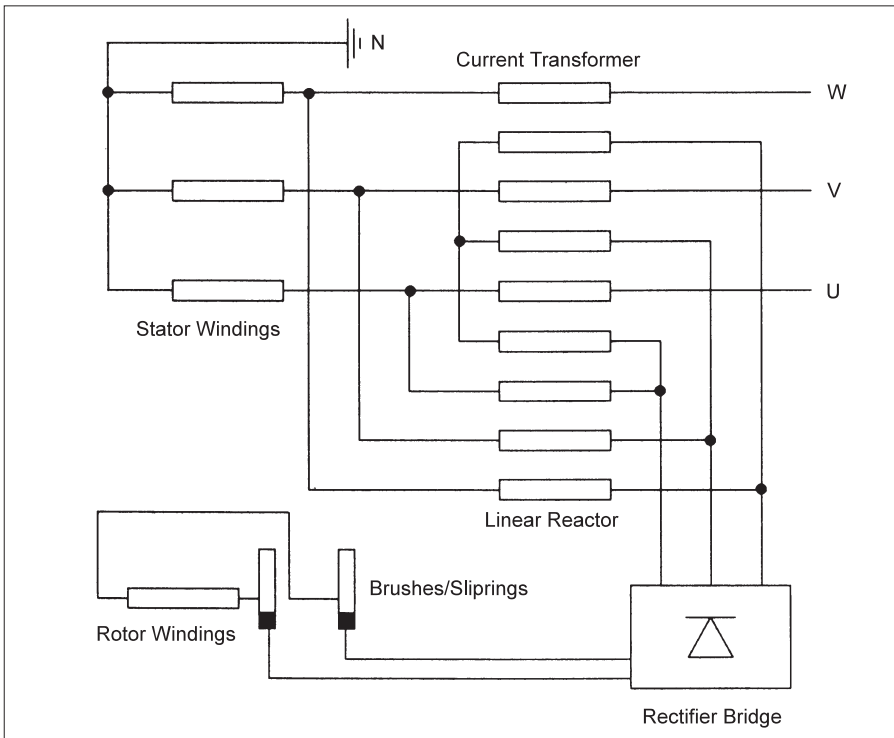

SECTION 2

APPLICATION

2.1 STANDARDS

The generator has been designed to comply with the requirements of most International Standards and is suitable for operation in an ambient temperature of 40°C maximum.

2.2 AIRFLOW

The generator should be positioned so that the cooling air may enter and leave the machine without restriction. Inadequate ventilation to the generator will lead to serious overheating and subsequent damage to windings.

2.3 DIRECTION OF ROTATION

The generator is suitable for either direction of rotation.

2.4 DRIVE ARRANGEMENT

All models are designed to suit engines having a drive shaft/crankcase mounting arrangement to SAE J609a Flange A Extension 5 (3/4" Taper) or Flange B Extension 6 (7/8" Taper) depending upon output kW.

Two bearing drive arrangements are available with a 22mm diameter 45.5mm long shaft extension.

The minimum pulley pitch diameter to be used for belt driven application is 118mm with a maximum side loading of 700N, to achieve full output and a reasonable bearing life. If smaller pulleys are required refer to factory for maximum side load and bearing life. Where single bearing to two bearing conversion parts have been supplied fitting instructions are provided with the kit.

2.4.1 ROAD VEHICLE GENERATORS

A special two bearing arrangement is used for this application to accommodate high bearing loadings and vibration. The standard 22mm diameter, 45.5mm long shaft extension is used.

The minimum pulley pitch diameter to be used is 118mm with a maximum side loading of 1000N.

2.5 BEARINGS

The bearing is preloaded and sealed for life and should require no further attention. Care must be taken to ensure that the anti-creep circlip is correctly located in the groove before mating with the end bell bearing housing, i.e. the bump on the circlip is in the deepest part of the groove.

On two bearing machines the drive end bearing is a standard ball bearing sealed for life.

2.5.1 ROAD VEHICLE GENERATORS

These generators are fitted with larger bearings than standard. The drive end bearing is clamped in the drive end bracket and the non drive end bearing is fitted in a steel housing with an 'O' ring to prevent turning.

2.6 EARTHING

The generator is manufactured and delivered with the stator windings completely isolated from the frame; a suitable earth terminal is provided on the bearing support for bonding to the generating set frame.

Access to the earth terminal is gained by removal of the end cover.

2.7 LOADING

The generators are suitable for supplying, continuously, most types of load with a total load current not exceeding the current quoted on the nameplate. Two points should be noted however:

1. Engine Power.

The generator set output may be limited by the horsepower rating of the engine. As a guide the engine has to supply approximately two horsepower for each 1000 watts (1kW) of electrical load. Refer to factory for specific generator efficiency.

2. Electric Motor Loads.

The current taken by a motor on full load is shown on its nameplate, but it will be several times this value at the instant of starting even when there is no load on the motor. The actual value depends on the type of motor and the starting current should be checked before attempting to decide the size of generator required.

When starting a motor the total current including any other load should not exceed twice the full-load current of the generator on BL105 models. The total current should not exceed 1.5 times the full-load current on SL105 and TL105 models.

The total current during motor starting on CL models should not exceed 3 times the generator full load current. In this case the total kW during the starting period may exceed the generator rated kW and it is essential to ensure that the selected engine is capable of providing the kW required. As a guide the engine rating should be approximately 3 HP for each 1000 watts (1kW) of the starting kW. Refer to the factory for specific applications.

SECTION 3

INSTALLATION

3.1 SAFETY WARNINGS

The generator is supplied as a component part for installation on a generating set and it is the responsibility of the generating set builder to fit the safety warning label, illustrated right, which is supplied packaged with this manual. The label should be attached to the generator in a position where it is clearly visible on the generating set.

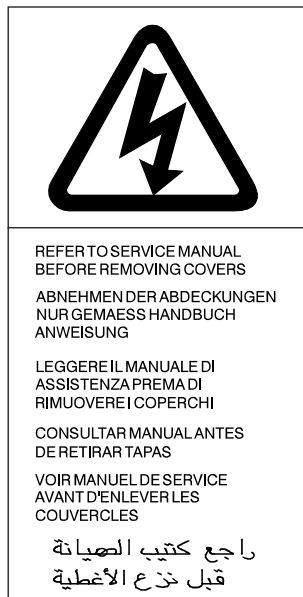

3.2 INSPECTION

When the equipment is received all details, especially the Serial Number of the generator, should be checked against the Advice Note. Carefully remove all dust and packing materials. In the event of any part being damaged or missing, this should be reported at once to the manufacturer and the transport company. Always quote the Serial Number on correspondence with the manufacturer.

When nameplates are supplied packaged with the machine, but not fitted, it is the responsibility of the installer to fit the nameplate to the generator.

3.3 COUPLING TO ENGINE

Refer to Assembly/Dismantling Procedure. SECTION 5.

3.4 ELECTRICAL CONNECTIONS

The generators are supplied from the factory with flying leads from the main stator windings. The BL105, NL105 & SL105 may be permanently connected or switched in the generator set outlet box to obtain the required output voltage(s). The installer must provide necessary overload protection. The windings are not bonded to the machine frame and it is the responsibility of the installer to provide suitable bonding to earth. Reference should be made to relevant site or safety regulations. Note that the point of earthing the stator winding is at the discretion of the installer.

Normally a 230 volt 2 wire output will be earthed at one end giving a maximum of 230 volts to earth (Or 115 volts in parallel mode).

A 110 volt 2 wire output will normally be earthed at the centre tap (series connection point) giving a maximum of 55 volts to earth.

The standard TL105 arrangement provides six line output leads for connection in Star or Delta configuration.

The CL105 generator may be supplied with flying leads from the main stator windings terminated in a socket and separate excitation control components, or as a complete generator package with control components located in a generator mounted box with output terminals. The neutral of the windings on the CL generator is connected to the frame earth terminal.

When separate excitation components are supplied, interconnection between them is made with multipin sockets and plugs. The installer must provide mounting for the components and ensure adequate ventilation. Refer to the factory if in doubt.

Reference should be made to relevant site or safety regulations.

3.5 VOLTAGE SELECTION

1. Dual Voltage Output

The main stator windings are in two sections which may be connected in series or parallel to give a choice of output voltage. For example, series connection gives 230V, parallel connection gives 115V.

This is illustrated below. Each winding section is capable of carrying the same current I . When the windings are connected in series the maximum load current is I , but when the windings are connected in parallel the maximum current is $2 \times I$.

Example:

A 2.5kVA generator when connected in series for 230V operation has a capacity of 10.9A; when connected in parallel for 115V it has a capacity of 21.7A.

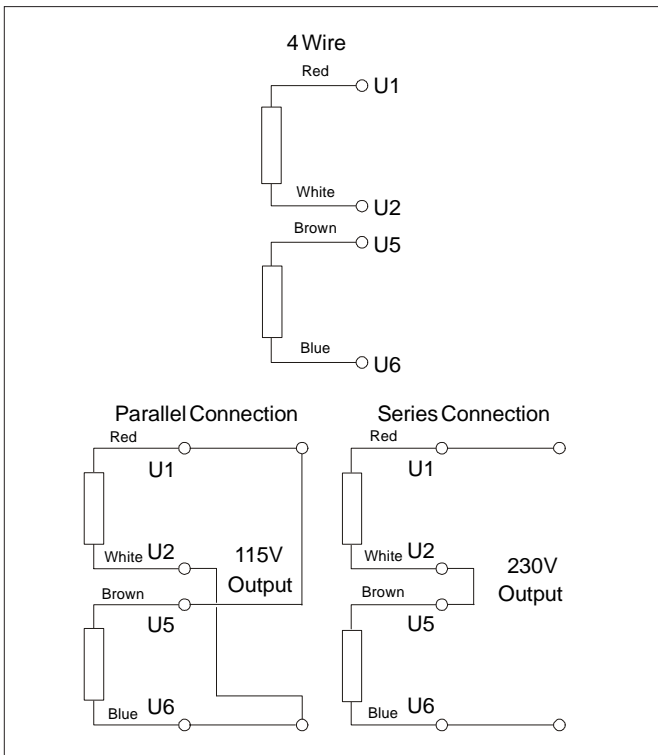

2. 110V CTE Output (BL105 range only).

The main stator windings are in two sections which should be connected in series to give 110V output, with the centre tap taken from the series connection point.

3.6 VOLTAGE ADJUSTMENT FOR THE SL105 - AVR MD1C

The voltage is set during manufacture to give the mid-voltage of the range of voltages shown on the nameplate, ie: a generator whose nameplate is marked 220-240/110-120V will be set to give 230 volts with the output windings connected in series and 115 volts when connected in parallel.

The voltage may be reset to any value within the nameplate range. To RAISE the voltage turn the volts adjust potentiometer VR1 CLOCKWISE and to LOWER the voltage turn the potentiometer ANTI-CLOCKWISE.

The volts adjust potentiometer is the one at the bottom of the board.

STABILITY

This control should not normally require adjustment having been set during manufacture, but should the output voltage fluctuate with a steady load connected, this may be improved by turning the potentiometer anti-clockwise which will increase the damping effect.

Note

1. Do not use undue force when turning the potentiometers - they can be damaged by attempting to adjust beyond the internal stops.
2. When making either adjustment the speed must be correct.

TL Models

TL generators have a voltage range of approximately 5%, e.g. 380 - 415 volts.

Voltage adjustment is effected by adjustment of the 'SET VOLTS' control potentiometer located on the AVR. Access to the AVR is gained by removal of the cover of the black, side mounted box.



Danger !

Removal of the air intake cover allows access to 'LIVE' parts. Only persons qualified to carry out electrical servicing should carry out adjustments.

TL generators may be supplied with a 12 lead winding suitable for series/parallel connection.

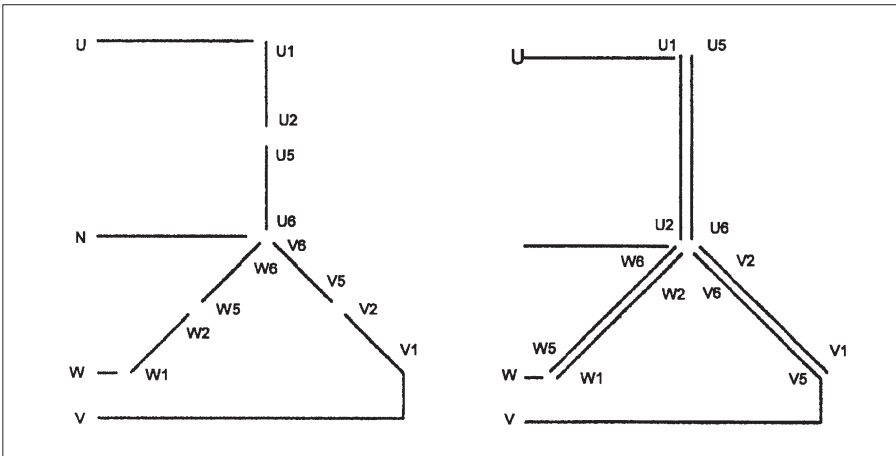

The installer must provide suitable terminations or switching arrangements to provide a safe reconnection means.

CL Models

CL generators are factory set and require no adjustment.

Should the voltage be incorrect at no-load, switch load (at least 50%) on and off and recheck voltage. (Voltage will normally rise after application of load.) If voltage is still incorrect adjustment can be made as follows:-

First check that the speed is correct (normally 3150 rpm no-load and 3000 rpm on load for 50Hz generators or 3790 rpm and 3600 rpm respectively for 60Hz generators).

The linear reactor controls the no-load voltage by adjustment of its airgap. Increasing gap increases voltage; decreasing gap decreases voltage. To adjust the airgap length, slacken the clamping bolts across the top of the reactor and adjust the thickness of packing in the 'airgap'. Packing must be non magnetic material.

After each adjustment, switch load (at least 50%) on and off and recheck no-load voltage.



Danger ! Air gap adjustment should be made in small increments, and should only be carried out by personnel qualified to perform electrical service.

SECTION 4

SERVICE & MAINTENANCE



Warning !

The following procedures present hazards which can result in personal injury or death. Only persons qualified to carry out electrical and mechanical servicing should undertake this work.

4.1 GENERAL

The BL model generator is fitted with sealed for life bearings and requires no regular maintenance.

The NL, SL, TL and CL models similarly require no regular mechanical maintenance. They are, however, fitted with sliprings and brushgear which require regular attention.

Inspect brushes and sliprings at 500 hours intervals. Replace brushes when they are worn to a depth of 8mm. The new brush should be bedded using a medium grade abrasive cloth. If the sliprings are pitted or badly marked the rotor should be removed and the sliprings lightly skimmed.

The generator must periodically be inspected and any accumulation of dirt or oil must be removed. Air inlet and outlet openings must be kept unobstructed.

For BL, NL, SL, TL, and CL models it is recommended that:-

- 1) after storage or long periods of standing idle the condition of windings should be checked. Refer to 'Insulation Resistance Check' subsection 4.2,

and

- 2) during generating set overhaul, the bearing is replaced. Refer to Assembly/Dismantling Procedure, Section 5.

4.2 INSULATION RESISTANCE CHECK

If the equipment has been stored or allowed to get damp the insulation resistance of the windings should be checked.

On BL models before carrying out this test disconnect the capacitor and any earthed connections.

On NL models disconnect rectifier, surge suppressor and any earthed connections.

On SL models disconnect AVR, rectifier, RFI suppressor and any earthed connections.

On TL models disconnect AVR and RFI suppressor and any earthed connections.

On CL models disconnect the three a.c. Input leads to the rectifier bridge and any earthed connection.

The check should be carried out on the stator winding between each winding group and the generator frame, and between the rotor winding and rotor core using a 500 volt Megger or similar instrument. The resistance value obtained should be at least one megohm. If the resistance is less than one megohm the windings should be dried out in a warm atmosphere. The resistance values should be rechecked every 30 minutes until this value is obtained.

4.3 FAULT FINDING

Should a fault develop during operation it is best identified by carrying out the checks identified in the following fault finding guides.

Refer to Assembly/Dismantling section when attempting to replace components.

Before proceeding always check security of all connections, especially those to control equipment and/or AVR.

On NL, SL, TL and CL models remove air intake cover and check condition of the sliprings, the freedom of movement of brushes, brush spring tension and amount of brushwear. Brushes should not be less than 8mm long.

BL MODEL - FAULT FINDING GUIDE

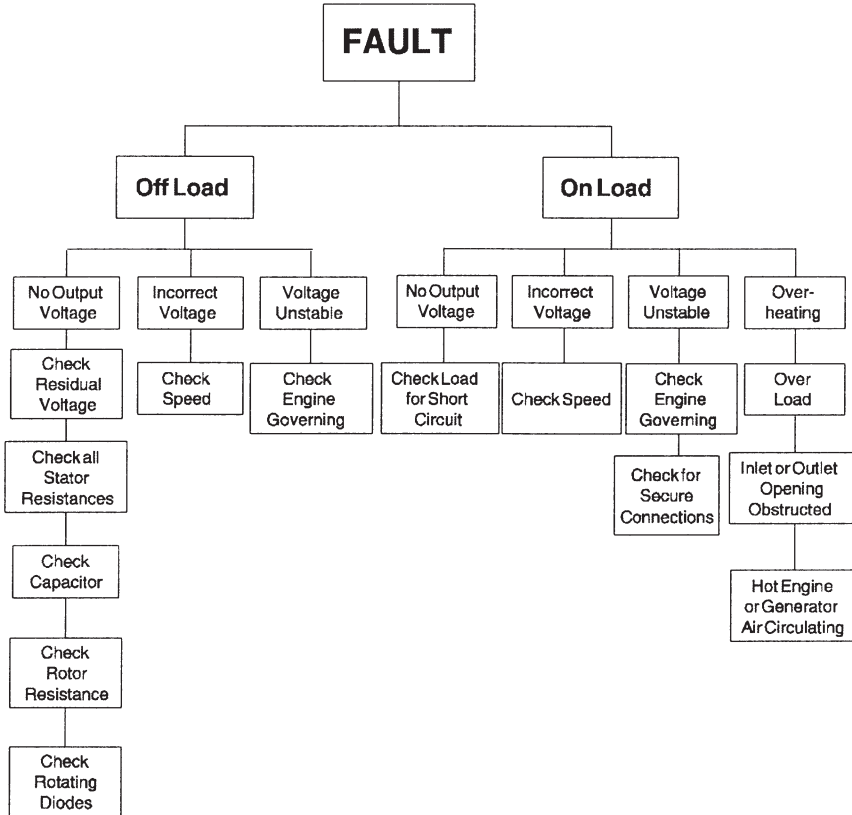

NL MODEL - FAULT FINDING GUIDE

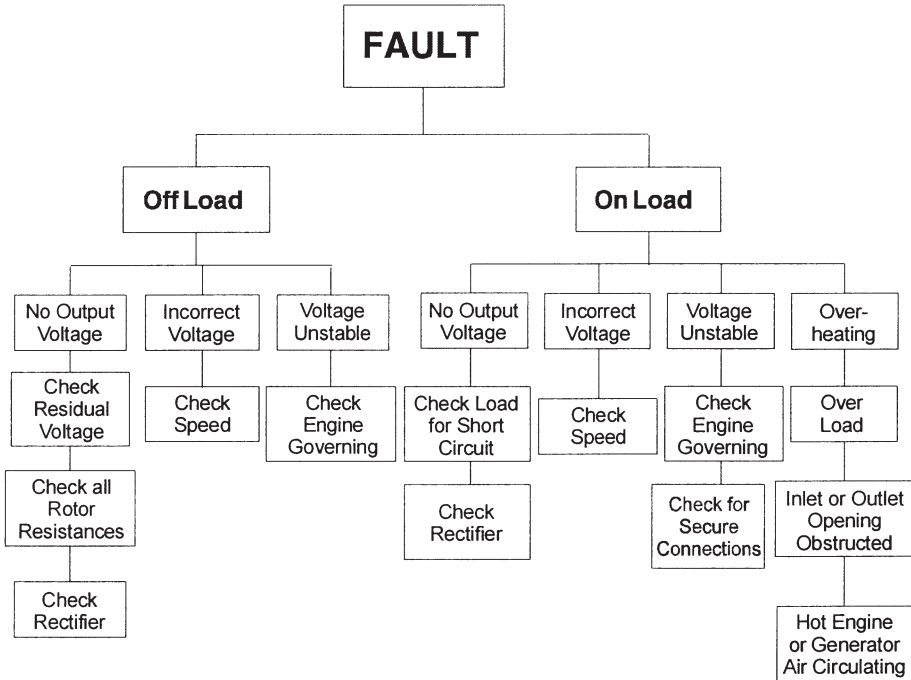

SL MODEL - FAULT FINDING GUIDE

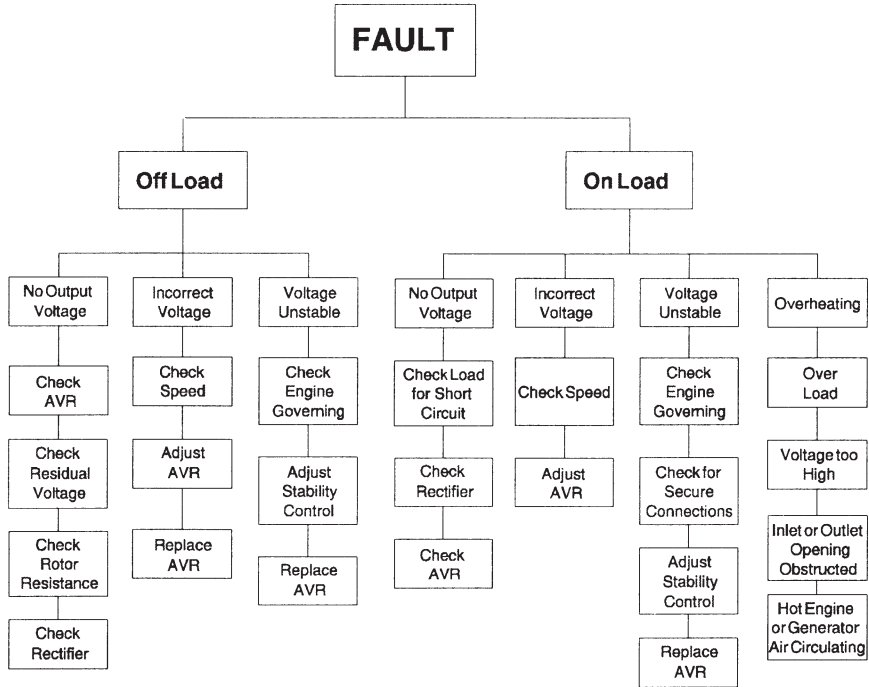

TL MODEL - FAULT FINDING GUIDE

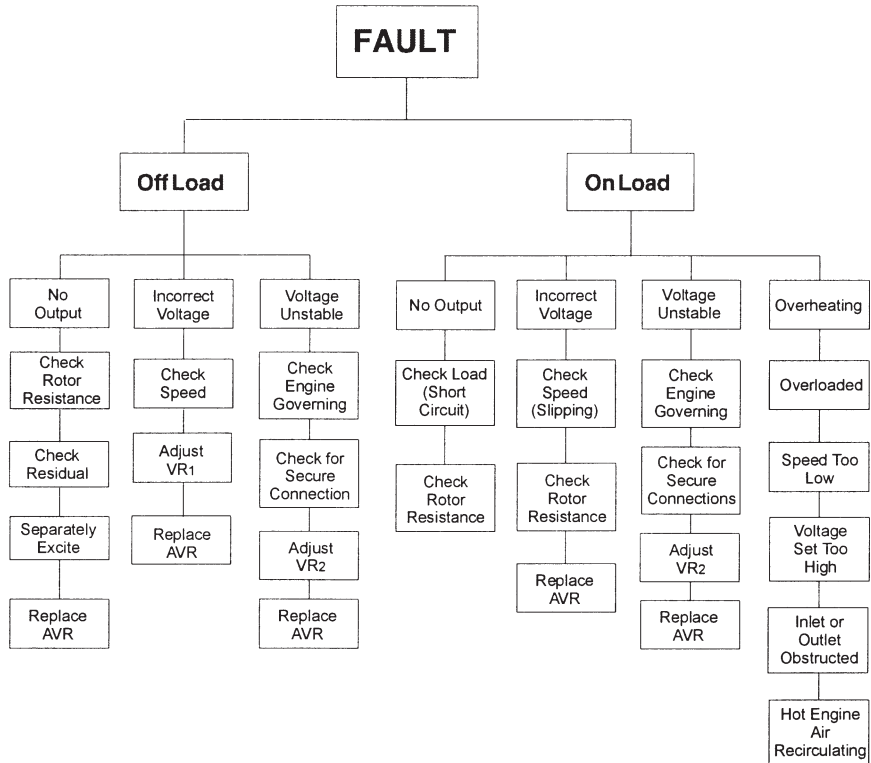

CL MODEL - FAULT FINDING GUIDE

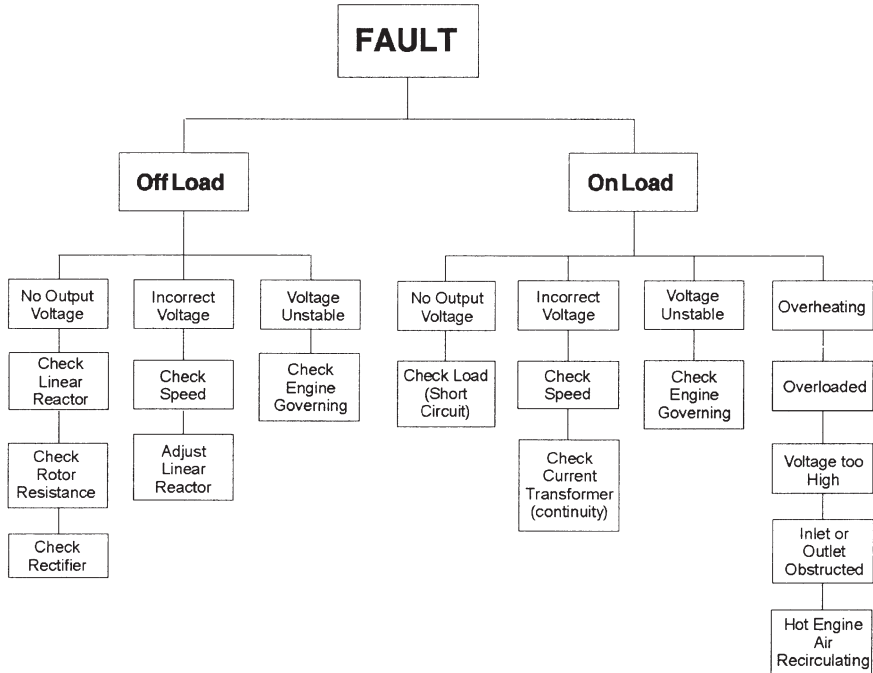

4.4 RESIDUAL VOLTAGE/FIELD FLASHING

If the rotor has been removed, the generator stored for a considerable time or the rotor (field) connections reversed during servicing, the residual magnetism may have been destroyed.

To check residual voltage remove the end cover for access.

Remove capacitor lead (BL model), Z2 from the rectifier assembly (SL and NL models), leads F1 -F2 from brush holders (TL and CL models).

Run the generator at normal no-load speed. Measure the voltage as indicated below:

Model	BL105	across output leads U1 — U2 Voltage	1.5 (min)
	SL 105	across output leads U1 — U2 Voltage	1.5 (min)
	NL 105	across output leads U1 — U2 Voltage	1.5 (min)
	CL 105	across output leads U — V Voltage	8 (min)
	TL 105	across AVR terminals 7 - Z2	3.5 (min)

BL Model

Reconnect capacitor lead to original position. Run generator at normal no-load speed. A 12 volt battery should then be instantaneously 'flashed' (that is connected for only one second) across the capacitor. The auxiliary leads must still be connected to the capacitor. The output voltage should then build up to the normal no-load level.

SL, NL, TL and CL Models

Reconnect lead Z2 to rectifier assembly and disconnect leads F1 - F2 (SL and NL models only). Run generator at normal no-load speed and apply a 12 volt supply, from the battery, to the brush -holder for about 3 seconds. Ensure the positive lead is applied to the brush holder nearest the bearing housing.

The output voltage of the generator, with the 12 volt supply connected, should be approximately normal voltage.

Stop the generator and reconnect leads F1 - F2.

Important ! Ensure the battery leads are connected to the brush holder with the correct polarity, and leads F1 - F2 are isolated from each other and earth.

4.4.1 LINEAR REACTOR CHECK

Check windings for continuity and resistance values to the following table (Subsection 4.5).

Check air gap adjustment. Refer to Subsection 3.5.

4.4.2 CURRENT TRANSFORMER CHECK

Check windings for continuity and resistance values to the following table . (Subsection 4.5).

4.5 RESISTANCE CHARTS

All figures are approximate values in ohms.

Main stator values are based on 50Hz windings.

60Hz windings at listed voltages will have values of 0.7 times the 50Hz value.

MODEL	VOLTAGE	ROTOR	MAIN STATOR PER SECTION	AUXILIARY WINDING
BL105A	115/230	7.9	1.0	1.29
BL105B		8.12	0.8	1.0
BL105C		8.6	0.64	1.1
BL105D		9.09	0.5	0.86
BL105E		9.57	0.41	1.07
BL105F		10.05	0.31	0.88
BL105G		10.53	0.28	0.74
BL105A	55/0/55	7.9	0.21	1.29
BL105B		8.12	0.18	1.04
BL105C		8.6	0.14	1.1
BL105D		9.09	0.12	0.86
BL105E		9.57	0.098	1.07
BL105F		10.05	0.074	0.85
BL105G		10.53	0.064	0.74
NL105E	220	10.8	0.35	2.19
NL105F		11.3	0.135	2.17
NL105G		11.9	0.113	1.99
SL105A	115/230	11.1	1.32	4.24
SL105B		11.5	0.86	4.17
SL105C		12.2	0.66	3.18
SL105D		12.8	0.54	2.85
SL105E		10.8	0.43	2.16
SL105F		11.3	0.36	1.94
SL105G		11.9	0.28	1.77
SL105A	55/0/55	11.1	0.29	4.24
SL105B		11.5	0.21	4.17
SL105C		12.2	0.16	3.18
SL105D		12.8	0.13	2.85
SL105E		10.8	0.11	2.16
SL105F		11.3	0.09	1.94
SL105G		11.9	0.065	1.77

MODEL	VOLTAGE	ROTOR	STATOR MAIN	STATOR AUX	WDG N°
TL105E	380/415	10.8	2.3	5.3	E9426
TL105E	220/240	10.8	0.81	5.3	E9416
TL105E	208/240	10.8	0.575	5.3	E9436
TL105F	380/415	11.3	1.7	5.1	F9426
TL105F	220/240	11.3	0.59	5.1	F9416
TL105F	208/240	11.3	0.425	5.1	F9436
TL105G	380/415	11.9	1.50	4.7	G9426
TL105G	220/240	11.9	0.49	4.7	G9416
TL105G	208/240	11.9	0.38	4.7	G9436

MODEL	VOLTAGE	ROTOR TOTAL OHMS	STATOR OHMS /PHASE	LINEAR REACTOR OHMS /PHASE	CURRENT TRANSFORMER OHMS /PHASE
CL105G	415	10.2	1.4	0.7	PR. 0.17
					SEC. 0.91



Warning!

Replace all guards and protective covers after servicing.
Failure to do so may result in operator personal injury.

SECTION 5

ASSEMBLY/DISMANTLING PROCEDURE

Component identification numbers refer to those shown in Generator Parts Identification (Pages 35, 37, 39, 41, 43 and 45).

5.1 ASSEMBLING GENERATOR TO ENGINE

Apply LOCTITE 'THREADLOCK' or equivalent to one end of the shaft securing stud [1]. Fit this end of the shaft securing stud [1] into the engine shaft, ensuring the full length of thread is engaged.

Fit appropriate engine adaptor plate and fit studs supplied into the generator side of the adaptor plate and tighten.

Remove end cover fixing screws [2] and end cover [3].

Remove transit bolt from shaft end and discard both bolt and large washer.

Important ! On NL, SL, TL, and CL models care must be taken to avoid damage to the carbon brushes by excessive axial movement of the rotor. Lift brushes if in doubt.

Offer stator frame assembly [4] complete with rotor assembly up to the engine, feeding rotor over securing stud and frame on to the adaptor studs. Tap frame over the adaptor spigot.

Fit nuts securing the frame to the adaptor studs and tighten.

Fit the 5/16" UNF SELF LOCKING nut (Shaft Securing Nut) [5] to the shaft securing stud [1] and tighten.

Replace end cover [3].

Secure stator frame assembly to the bedplate foot fixing(s). Where the stator frame assembly is rigidly mounted to the bedplate, shims must be fitted to ensure accurate alignment.

Refer to subsection 5.14 for torque settings.

5.2 DISMANTLING STATOR FRAME ASSEMBLY

Important ! On NL, SL, TL, and CL models remove end cover fixing screws [2] and end cover [3] and lift brushes [12] (part of brushbox assembly).

Remove nuts securing frame to adaptor studs.

Remove feet fixing bolts (or nuts).

Tap frame away from the engine to release the adaptor spigot. Withdraw stator frame assembly over the rotor.

5.3 WITHDRAWING ROTOR FROM ENGINE

Remove the shaft securing nut [5].

Release rotor from engine taper shaft by supporting rotor in one hand and with a hide mallet striking firmly on a pole face.

Important ! Do not use the fan [6] to prevent the rotor turning when releasing the shaft securing nut.

5.4 REMOVAL/REPLACEMENT OF CAPACITOR - BL MODELS

Remove end cover fixing screws [2] and end cover [3] and disconnect capacitor leads. Remove capacitor fixing nut [11] and cut nylon tie support [12] or remove capacitor fixing screw [18] and nut. Remove capacitor [13].

Replacement is a reversal of removal.

5.5 REMOVAL/REPLACEMENT OF DIODE VARISTOR ASSEMBLY - BL MODELS

Important ! Take careful note of connections and positions of the solder tags before carrying out the following procedure. Incorrect polarity of the diode varistor assembly will destroy residual magnetism.

Removal/replacement of diode varistor assembly and/or varistors is most easily carried out by removing end cover fixing screw [2] and end cover [3].

Support the rotor weight with a sling or block between the rotor and bedplate.

Unsolder leads from diode [14] pin, and unscrew diode stud. If the varistors [15] are to be replaced, unsolder varistor lead from solder tag [16] on the diode stud. Prise out the silicone sealant from the recess(es) in the diode carrier [17], and remove the varistor(s) [15].

Fit new diodes, placing solder tags on the diode studs and tighten to diode base with a nut before feeding through the diode carrier and securing with a second nut. Insert new varistor(s), leads first, and push varistor(s) body well down into the varistor carrier [17] recess(es). Solder leads to diode pin and the solder tag on the diode stud. Reseal with silicone sealant.

Important ! Nut threads should be treated with loctite 242, nuts to be torque tightened to 1.6Nm.

5.6 REMOVAL / REPLACEMENT OF AVR - SL MODELS

Remove end cover fixing screws [2] and end cover [3].

Disconnect the four leads (three black and one grey) from the four spade terminals on the right hand side of the AVR, taking note that the grey lead is always connected to the terminal marked F1.

Remove the three AVR fixing screws [13] and remove AVR [14]. Replacement is a reversal of removal. Ensure that the leads to the AVR are correctly replaced and the grey lead is connected to terminal F1.

If grey (F1) and black (F2) leads are reversed it will be necessary to 'flash' the field when restarting. Refer to subsection 4.4.

5.7 REMOVAL/REPLACEMENT OF AVR - TL MODELS

Remove the 4 fixing screws and pull the lid of the box containing AVR away.

Disconnect all AVR leads.

Remove the 4 AVR fasteners.

Lift away AVR.

Replacement is a reversal of removal. Ensure that AVR leads are correctly replaced.

5.8 REMOVAL/REPLACEMENT OF DIODE BRIDGE - SL and NL MODELS

Important ! Note positions of leads on the assembly before removal.

Remove end cover fixing screws [2] and end cover [3].

Remove leads from diode bridge [16]. Remove diode bridge fixing screw [22] and remove diode bridge.

Replacement is a reversal of removal.

5.9 REMOVAL/REPLACEMENT OF CHOKE - SL and NL MODELS

Remove end cover fixing screws [2] and end cover [3].

Remove diode bridge fixing screws [22]. Lift away choke and remove connecting leads. Remove choke [15].

Replacement is a reversal of removal.

5.10 REMOVAL/REPLACEMENT OF RADIO INTERFERENCE SUPPRESSOR (RIS) - NL, SL and TL Models when applicable

Remove connecting leads.

Remove RIS fixing screw [19] and remove RIS [17]. Replacement is a reversal of removal.

Important ! Ensure that the RIS spacer [20] is fitted between the RIS and frame.

5.11 REMOVAL/REPLACEMENT OF BEARING

With the rotor withdrawn, use a standard bearing puller to remove the bearing from the shaft. Place new bearing squarely on the shaft end with anti-creep circlip groove inboard and drift into place using a suitably sized soft tubular drift on the bearing inner race.

Care must be taken to ensure that the anti-creep circlip is correctly located in the groove before mating with the bearing housing, i.e. the bump on the circlip is in the deepest part of the groove.

Refit the rotor assembly into the stator frame assembly taking care to avoid damaging wound components. Locate the bearing in the housing and tap into position.

Important ! On NL, SL, TL and CL models ensure brushes are lifted before attempting to refit the rotor assembly into the stator frame assembly.

Assemble generator to engine. Refer to subsection 5.1.

5.12 REMOVAL/REPLACEMENT OF BRUSHES/BRUSH CALLIPER ASSEMBLY - CL MODELS

Disconnect brush leads. Pull callipers [12] fully open. Remove brush arm assembly securing nut [17].

Ease brush assembly from brush arm mounting bracket [18] and lift away.

If brushes only are to be replaced pull calliper arms open, remove brush and press new brush into place.

Replacement is a reversal of removal.

Caution ! Brushes should be bedded after removal or replacement. Refer to subsection 4.1

5.13 REMOVAL/REPLACEMENT OF BRUSHES/BRUSHBOX ASSEMBLY - NL, SL, & TL MODELS

Remove end cover fixing screws [2] and end cover [3].

On SL models remove AVR [14]. Refer to subsections 5.6 and 5.7.

Remove fixing screw [21] and lift away brushbox assembly.

Replacement is a reversal of removal.

On SL models refit AVR as detailed in subsections 5.6 and 5.7.

If brushes only are to be changed remove brush terminal plate and withdraw springs and brushes. New brushes must be bedded using a medium grade abrasive cloth.

5.14 TORQUE SETTINGS

Adaptor to engine	-	Refer to engine manufacturer.
Adaptor to frame	-	5.4Nm (0.55 kgf.m)
Shaft securing nut	-	20.4Nm (2.1 kgf.m)

Caution ! After servicing ensure all protective guards and access covers are fitted. Failure to do so can result in operator injury.

SECTION 6

SPARES AND AFTER SALES SERVICE

6.1 RECOMMENDED SPARES

Service parts are conveniently packaged for easy identification.

We recommend the following for service and maintenance. In critical applications a set of these service spares should be held with the generator.

Description	Part No.	Quantity
BL105 Models		
1. Capacitor	009-092 40mfd	1
2. NDE Bearing	014-040	1
3. NDE Bearing - R.V.G.	014-041	1
4. DE Bearing - 2 Bearing	014-003	1
5. DE Bearing - R.V.G.	014-042	1
6. Diode Varistor Assembly	B105Z-11001	1

Note: R.V.G. refers to Road Vehicle Generator.

NL105 Models

1. Surge Suppressor Assembly	036-116	1
2. Diode Bridge	002-058	1
3. NDE Bearing	014-040	1
4. DE Bearing - 2 Bearing	014-003	1
5. Brushbox (including brushes)	011-008	1
6. Brush	010-026	2

SL Models

1. AVR	036-245	1
2. Diode Bridge	002-058	1
3. NDE Bearing	014-040	1
4. DE Bearing - 2 Bearing	014-003	1
5. Brushbox (including brushes)	011-008	1
6. Brush	010-026	2

TL105 Models

1. AVR	E000-24105	1
2. Brush Box (including brushes)	011-008	1
3. Brush	010-026	2
4. NDE Bearing	014-040	1
5. DE Bearing	014-003	1

CL105 Models

1. Diode Bridge	002-058	2
2. Brush Holder	011-001	2
3. Brush	010-024	4
4. NDE Bearing	014-040	1
5. DE Bearing - 2 Bearing	014-003	1

When ordering spare parts the machine serial number and type should be quoted, together with the part description. The serial number is on the side of the generator.

Orders and enquiries for parts should be addressed to:

Newage International Limited
Markon Division
Lands End Way
Oakham
Rutland
LE15 6QF
ENGLAND

Telephone: 44 (0) 1572 723811

Fax: 44 (0) 1572 756856

Or any of our subsidiary companies listed on the back cover.

6.2 AFTER SALES SERVICE

A full technical advice and on-site service facility is available from our Service Department in Oakham or through our Subsidiary Companies.

A repair facility is also available from our office in Oakham.

BL105 PARTS IDENTIFICATION - SINGLE BEARING

Plate Ref	Description
1	SHAFT SECURING STUD
2	END COVER FIXING SCREWS
3	END COVER
4	STATOR FRAME ASSEMBLY
5	SHAFT SECURING NUT
6	FAN
7	WOUND ROTOR ASSEMBLY
8	BEARING
9	AIR BAFFLE
10	INSULATING BUSH
11	CAPACITOR FIXING NUT
12	CAPACITOR SUPPORT
13	CAPACITOR
14	DIODE (Forward)
14A	DIODE (Reverse)
15	VARISTOR
16	SOLDER TAG
17	DIODE/VARISTOR CARRIER HUB
18	DIODE/VARISTOR HUB ASSEMBLY
19	CAPACITOR FIXING SCREW

TYPICAL BL105 GENERATOR - SINGLE BEARING

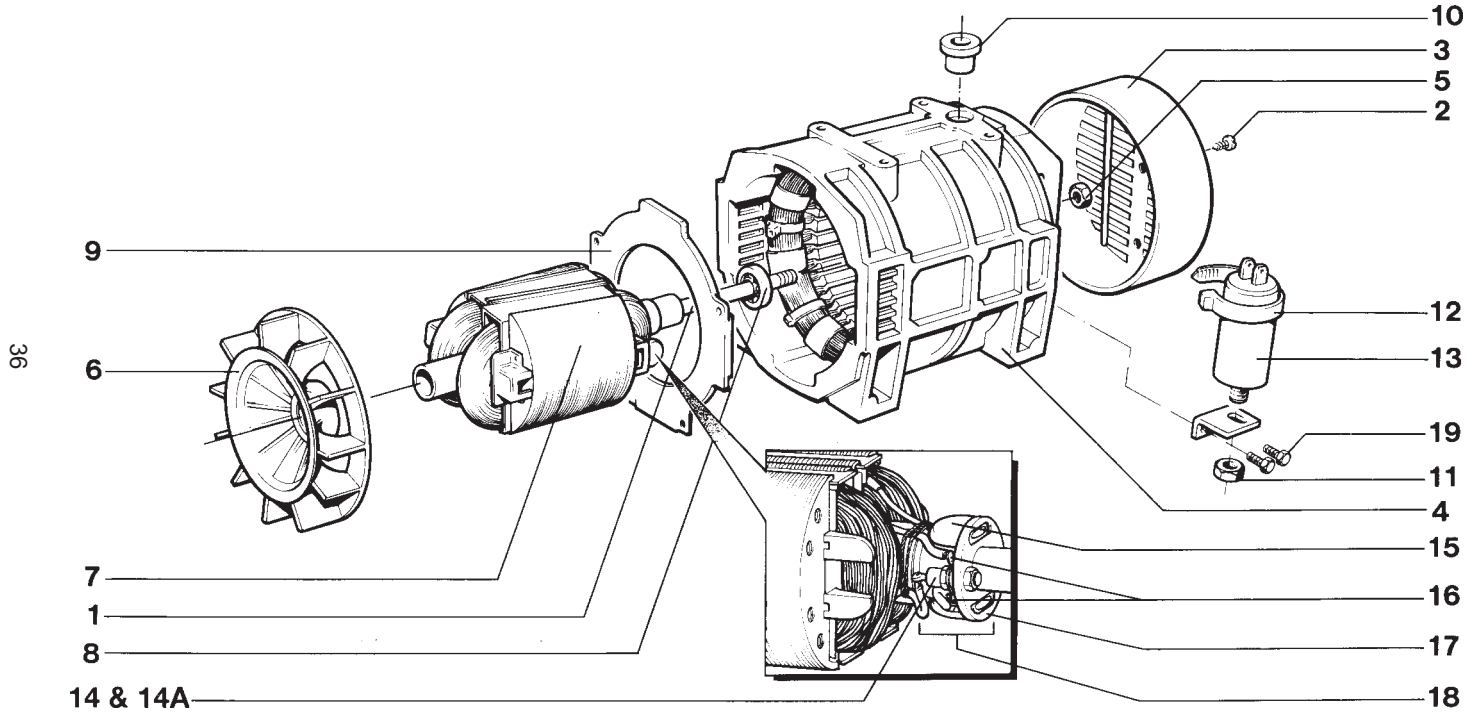

NL105 PARTS IDENTIFICATION

Plate Ref	Description	Plate Ref	Description
1	SHAFT SECURING STUD	17	RADIO INTERFERENCE SUPPRESSOR (RIS)
2	END COVER FIXING SCREWS	18	BRUSHBOX MOUNTING PLATE
3	END COVER	19	RIS FIXING SCREW
4	STATOR FRAME ASSEMBLY	20	RIS INSULATING SPACER
5	SHAFT SECURING NUT	21	BRUSHBOX FIXING SCREW
6	FAN	22	DIODE BRIDGE FIXING SCREW
7	WOUND ROTOR ASSEMBLY		
8	BEARING		
9	AIR BAFFLE		
10	INSULATING BUSH		
11	SLIPRINGS		
12	BRUSHBOX ASSEMBLY		
13	NUT		
14	SURGE SUPPRESSOR		
15	CHOKE		
16	DIODE BRIDGE		

TYPICAL NL105 GENERATOR

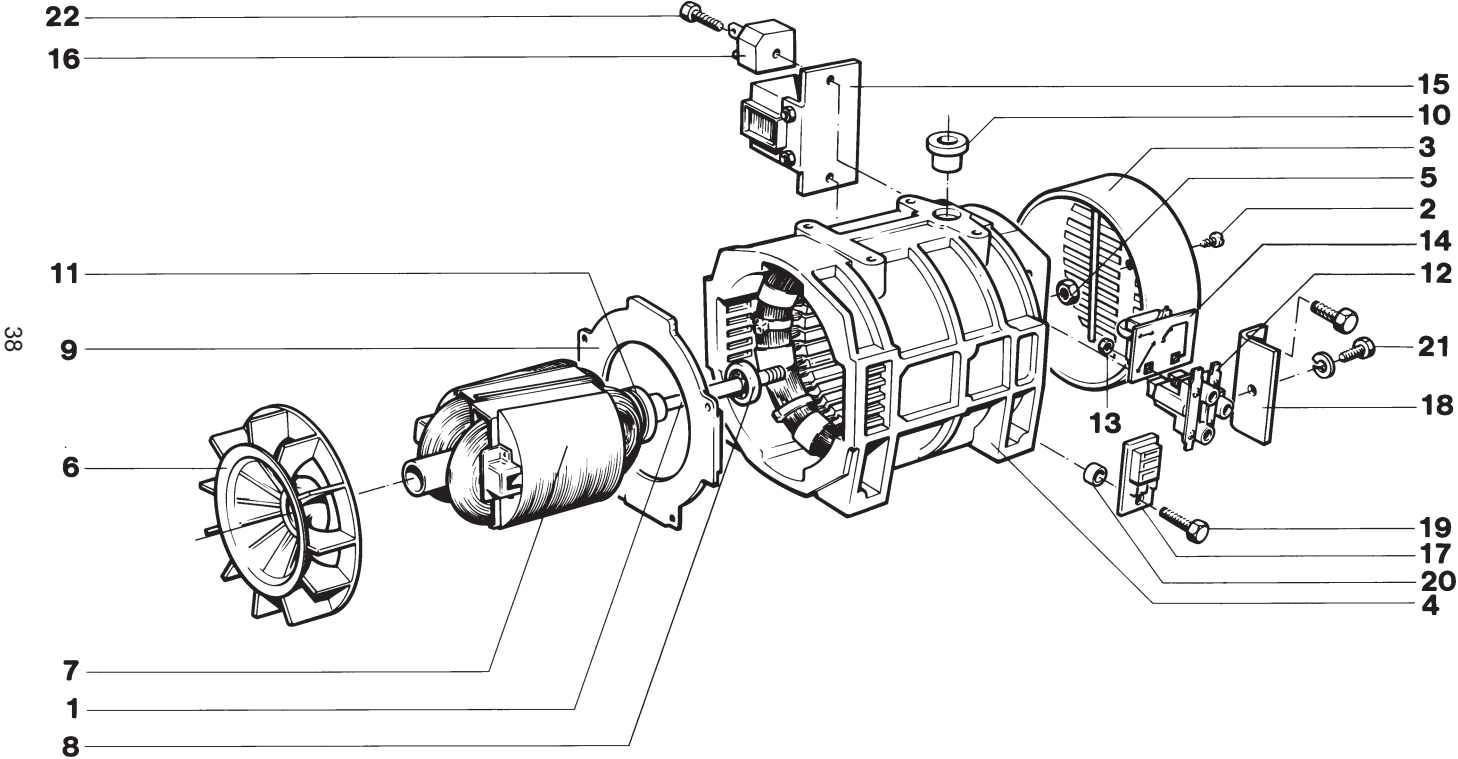

SL105 PARTS IDENTIFICATION

Plate Ref	Description	Plate Ref	Description
1	SHAFT SECURING STUD	17	RADIO INTERFERENCE
2	END COVER FIXING SCREWS		SUPPRESSOR (RIS)
3	END COVER	18	BRUSHBOX MOUNTING PLATE
4	STATOR FRAME ASSEMBLY	19	RIS FIXING SCREW
5	SHAFT SECURING NUT	20	RIS INSULATING SPACER
6	FAN	21	BRUSHBOX FIXING SCREW
7	WOUND ROTOR ASSEMBLY	22	DIODE BRIDGE FIXING SCREW
8	BEARING		
9	AIR BAFFLE		
10	INSULATING BUSH		
11	SLIPRINGS		
12	BRUSHBOX ASSEMBLY		
13	AVR FIXING SCREWS		
14	AUTOMATIC VOLTAGE REGULATOR (AVR)		
15	CHOKE		
16	DIODE BRIDGE		

TYPICAL SL105 GENERATOR

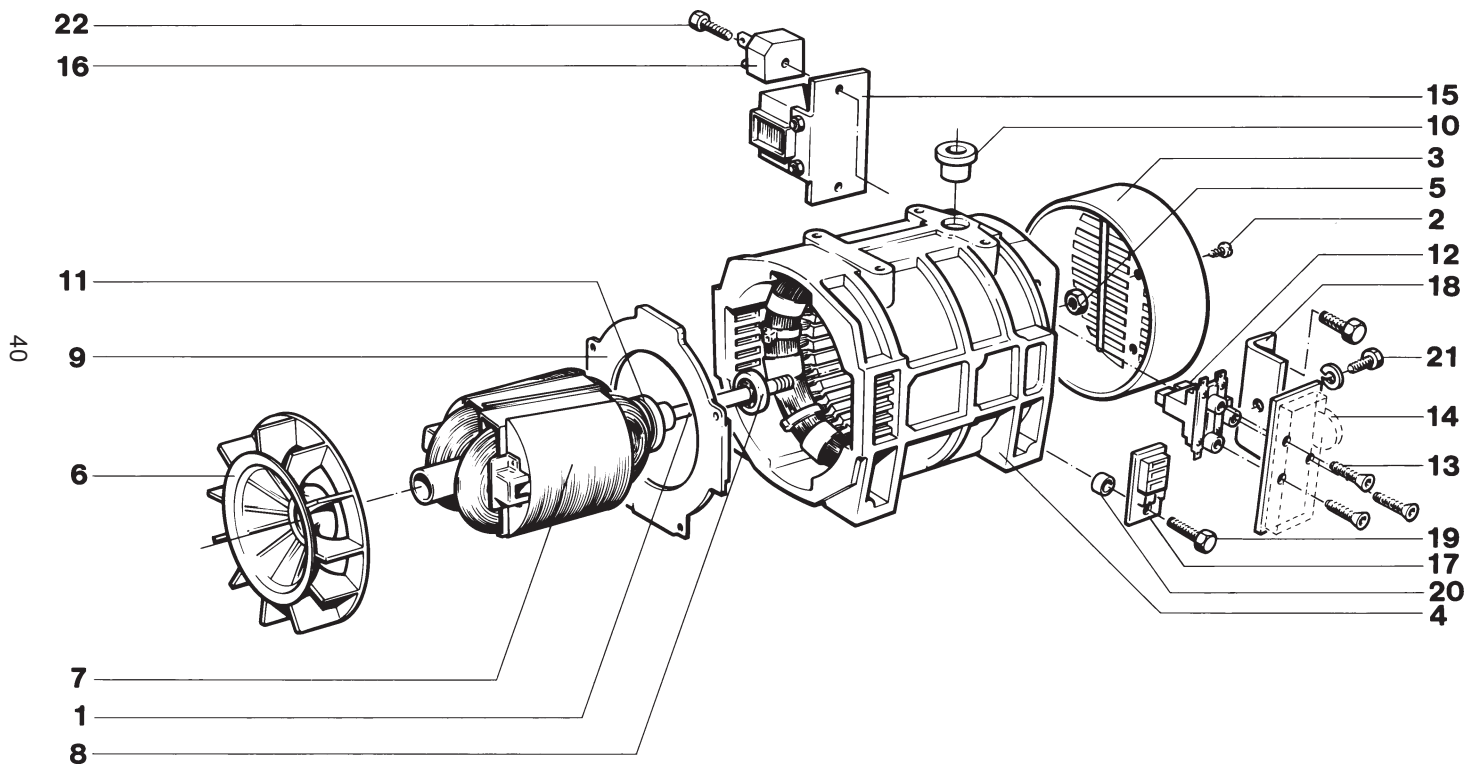

BL105 PARTS IDENTIFICATION - TWO BEARING

Plate Ref	Description	Plate Ref	Description
1	SHAFT SECURING STUD*	16	SOLDER TAG
2	END COVER FIXING SCREWS	17	DIODE/VARISTOR CARRIER HUB
3	END COVER	18	DIODE/VARISTOR HUB ASSEMBLY
4	STATOR FRAME ASSEMBLY	19	STUB SHAFT*
5	SHAFT SECURING NUT*	20	BEARING RETAINING SCREW
6	FAN	21	D.E. BRACKET
7	WOUND ROTOR ASSEMBLY	22	BEARING RETAINING WASHER*
8	BEARING - NON DRIVE END	23	BEARING - DRIVE END
9	AIR BAFFLE	24	BEARING RETAINING PLATE**
10	INSULATING BUSH	25	'O' RING**
11	CAPACITOR FIXING NUT	26	BEARING HOUSING**
12	CAPACITOR SUPPORT	27	D.E. BRACKET**
13	CAPACITOR	28	CAPACITOR SUPPORT FIXING SCREW**
14	DIODE		
15	VARISTOR		

* CONVERSION KIT ONLY

** ROAD VEHICLE GENERATORS ONLY

TYPICAL BL105 GENERATOR - TWO BEARING

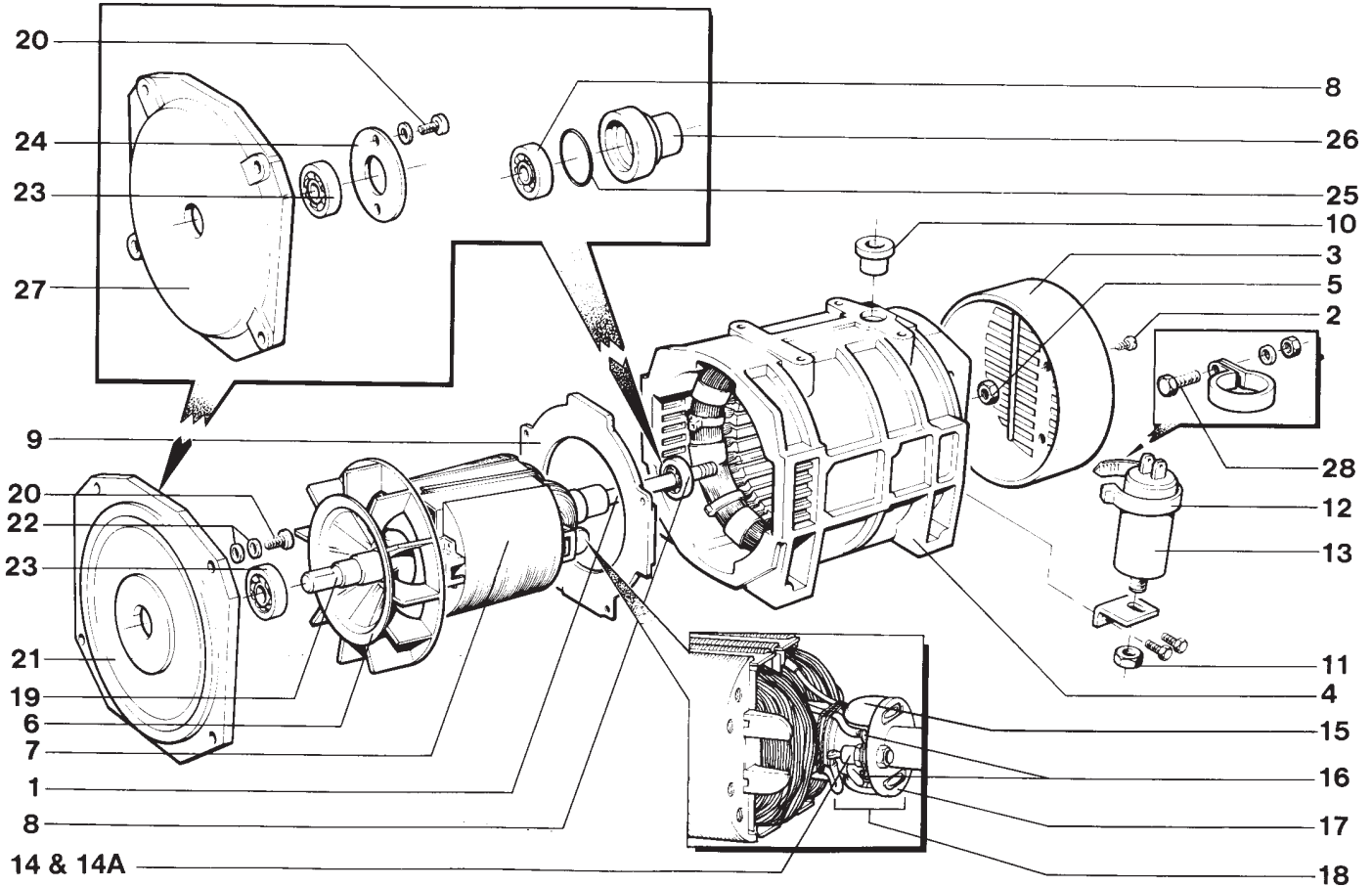

TL105 PARTS IDENTIFICATION

Plate Ref	Description	Plate Ref	Description
1	SHAFT SECURING STUD	17	RADIO INTERFERENCE SUPPRESSOR (RIS)
2	END COVER FIXING SCREWS	18	BRUSHBOX MOUNTING PLATE
3	END COVER	19	RIS FIXING SCREW
4	STATOR FRAME ASSEMBLY	20	RIS INSULATING SPACER
5	SHAFT SECURING NUT	21	BRUSHBOX ASSEMBLY FIXING SCREW
6	FAN		
7	WOUND ROTOR ASSEMBLY		
8	BEARING		
9	AIR BAFFLE		
10	INSULATING BUSH		
11	SLIPRINGS		
12	BRUSHBOX ASSEMBLY		
13	AVR FIXING SCREW		
14	AVR FIXING SCREW		
15	AVR HOUSING		
16	AVR		

TYPICAL TL105 GENERATOR

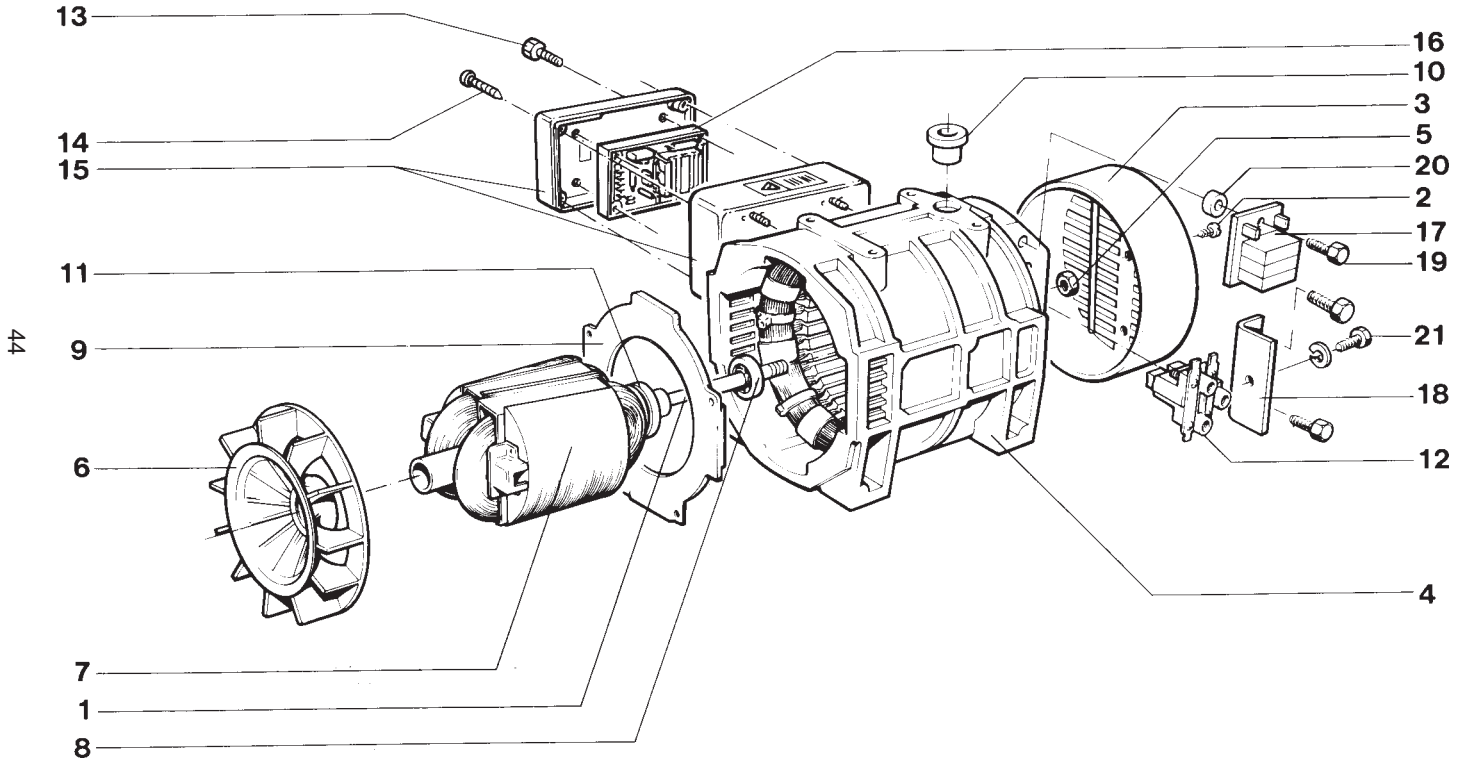

CL105 PARTS IDENTIFICATION

Plate Ref	Description	Plate Ref	Description
1	SHAFT SECURING STUD	17	BRUSH ARM ASSEMBLY
2	END COVER FIXING SCREWS		SECURING NUT
3	END COVER	18	BRUSH ARM MOUNTING
4	STATOR FRAME ASSEMBLY		BRACKET
5	SHAFT SECURING NUT	19	MULTIPIN SOCKET
6	FAN	20	MULTIPIN PLUG
7	WOUND ROTOR ASSEMBLY	21	CURRENT TRANSFORMER
8	BEARING	22	REACTOR
9	AIR BAFFLE		
10	INSULATING BUSH		
11	SLIPRINGS		
12	CALIPER BRUSH ASSEMBLY		
13	DIODE BRIDGE FIXING SCREW		
14	FIELD RESISTOR		
15	DIODE BRIDGES		
16	FIELD RESISTOR SUPPORT PLATE		

TYPICAL CL105 GENERATOR

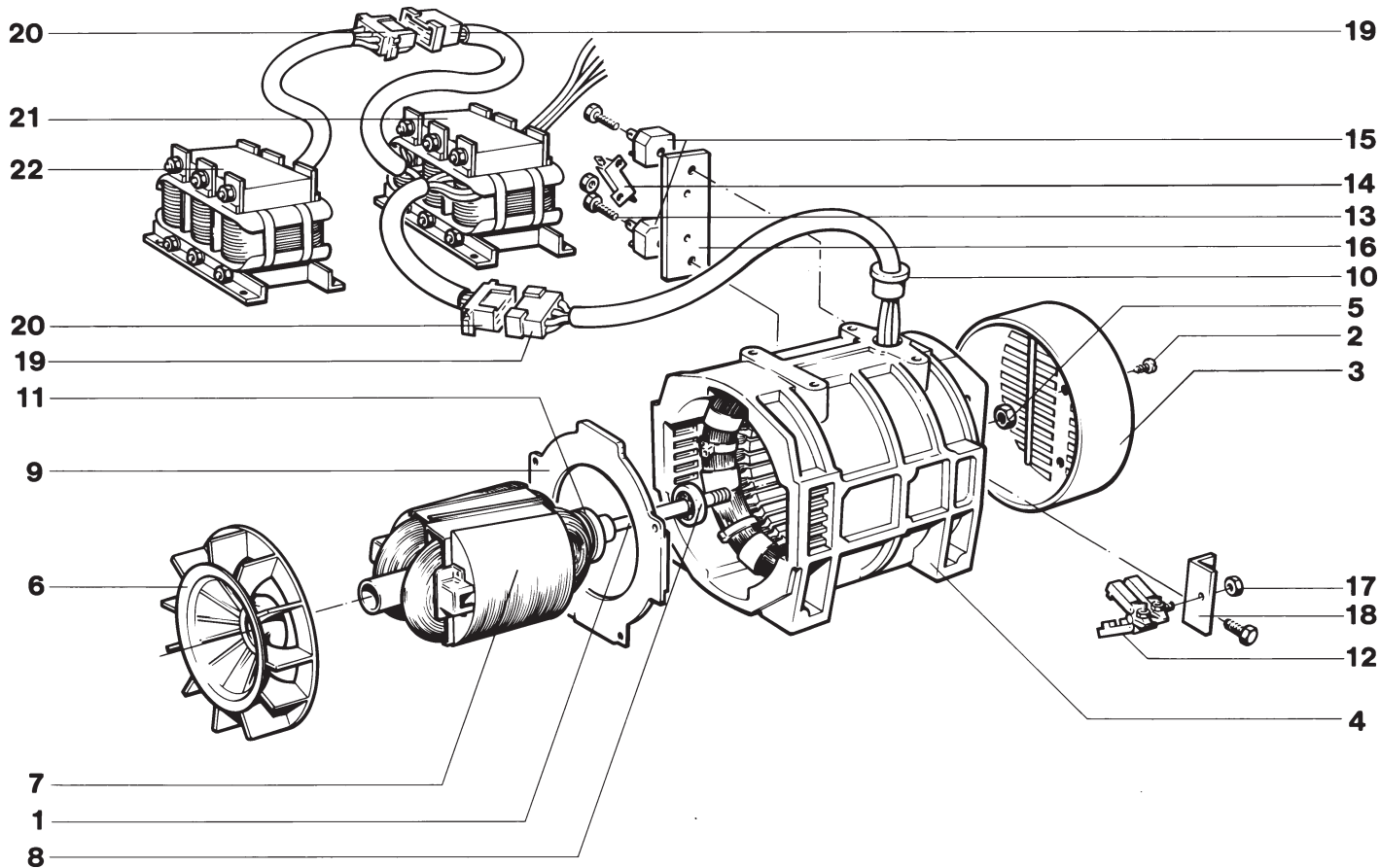

A.C. GENERATOR WARRANTY

DEFECTS AFTER DELIVERY

We will make good by repair or, at our option, by the supply of a replacement, any fault which under proper use appears in the goods within the period specified on Clause 12, and is found on examination by us to be solely due to defective material and workmanship; provided that the defective part is promptly returned, carriage paid, with all identification numbers and marks intact, to our works or, if appropriate, to the Dealer who supplied the goods.

Any part repaired or replaced, under warranty, will be returned by N.I. free of charge (via sea freight if outside the UK).

We shall not be liable for any expenses which may be incurred in removing or replacing any part sent to us for inspection or in fitting any replacement supplied by us. We shall be under no liability for defects in any goods which have not been properly installed in accordance with N.I. recommended installation practices as detailed in the publications 'N.I. Installation, Service and Maintenance Manual' and 'N.I. Application Guidelines', or which have been improperly stored or which have been repaired, adjusted or altered by any person except ourselves or our authorised agents, or in any second-hand goods, proprietary articles or goods not of our own manufacture although supplied by us, such articles and goods being covered by the warranty (if any) given by the separate manufacturers.

Any claim under this clause must contain full particulars of the alleged defect, the description of the goods, the date of purchase, and the name and address of the Vendor, the Serial Number (as shown on the manufacturers identification plate) or for Spares the order reference under which the goods were supplied.

Our judgement in all cases of claims shall be final and conclusive and the claimant shall accept our decision on all questions as to defects and the exchange of a part or parts.

Our liability shall be fully discharged by either repair or replacement as above, and in any event shall not exceed the current list price of the defective goods.

Our liability under this clause shall be in lieu of any warranty or condition implied by law as to the quality or fitness for any particular purpose of the goods, and save as expressly provided in this clause we shall not be under any liability, whether incontract, tort or otherwise, in respect of defects in goods delivered or for any injury, damages or loss resulting from such defects or from any work undone in connection therewith.

WARRANTY PERIOD

A.C. Generators In respect of a.c. generators the Warranty Period is eighteen months from the date when the goods have been notified as ready for despatch by N.I. or twelve months from the date of first commissioning (whichever is the shorter period)

Spares. In respect of Spares the Warranty Period is three months from the date of despatch by us or on fitment whichever is the earlier. These periods are subject to the exclusions and conditions specified in Clause 11.

MACHINE SERIAL NUMBER

--

NEWAGE INTERNATIONAL LIMITED

MARKON DIVISION
LANDS END WAY
OAKHAM
RUTLAND
LE15 6QF
ENGLAND

Telephone: 44 (0) 1572 723811
Fax: 44 (0) 1572 756856

REGISTERED OFFICE AND ADDRESS:
PO BOX 17
BARNACK ROAD
STAMFORD
LINCOLNSHIRE
PE9 2NB

Telephone: 44 (0) 1780 484000
Fax: 44 (0) 1780 484100
Web Site: www.newagestamford.com

SUBSIDIARY COMPANIES



1 AUSTRALIA: NEWAGE ENGINEERS PTY. LIMITED
PO Box 6027, Baulkham Hills Business Centre,
Baulkham Hills NSW 2153.
Telephone: Sydney (61) 2 9680 2299
Fax: (61) 2 9680 1545

2 CHINA: WUXI NEWAGE ALTERNATORS LTD
Plot 49-A, Xiang Jiang Road
Wuxi High - Technical Industrial Dev. Zone
Wuxi, Jiangsu 214028
PR of China
Telephone: (86) 51 027 63313
Fax: (86) 51 052 17673

3 GERMANY: NEWAGE ENGINEERS G.m.b.H.
Rotenbrückenweg 14, D-2213 Hamburg.
Telephone: Hamburg (49) 40 714 8750
Fax: (49) 40 714 87520

4 INDIA: C. G. NEWAGE ELECTRICAL LIMITED
C33 Midc, Ahmednagar 414111, Maharashtra.
Telephone: (91) 241 778224
Fax: (91) 241 777494

5 ITALY: NEWAGE ITALIA S.r.l.
Via Triboniano, 20156 Milan.
Telephone: Milan (39) 02 380 00714
Fax: (39) 02 380 03664

6 JAPAN: NEWAGE INTERNATIONAL JAPAN
8 - 5 - 302 Kashima
Hachioji-shi
Tokyo, 192-03
Telephone: (81) 426 77 2881
Fax: (81) 426 77 2884

7 NORWAY: NEWAGE NORGE A/S
Økern Naeringspark, Kabeigt. 5
Postboks 28, Økern, 0508 Oslo
Telephone: Oslo (47) 22 97 44 44
Fax: (47) 22 97 44 45

8 SINGAPORE: NEWAGE (FAR EAST) PTE LIMITED
10 Toh Guan Road #05-03
TT International Tradepark
Singapore 608838
Telephone: Singapore (65) 794 3730
Fax: (65) 898 9065

9 SPAIN: STAMFORD IBERICA S.A.
Ctra. Fuenlabrada-Humanes, km 2
Poligono Industrial "Los Linares"
C/Pico de Almanzor, 2
E-28970 HUMANES DE MADRID (Madrid)
Telephone: Madrid (34) 91 604 8987/8928
Fax: (34) 91 604 81 66

10 U.S.A.: NEWAGE LIMITED
4700 Main St, N.E.
Fridley
Minnesota 55421
Telephone: (1) 800 367 2764
Fax: (1) 800 863 9243