

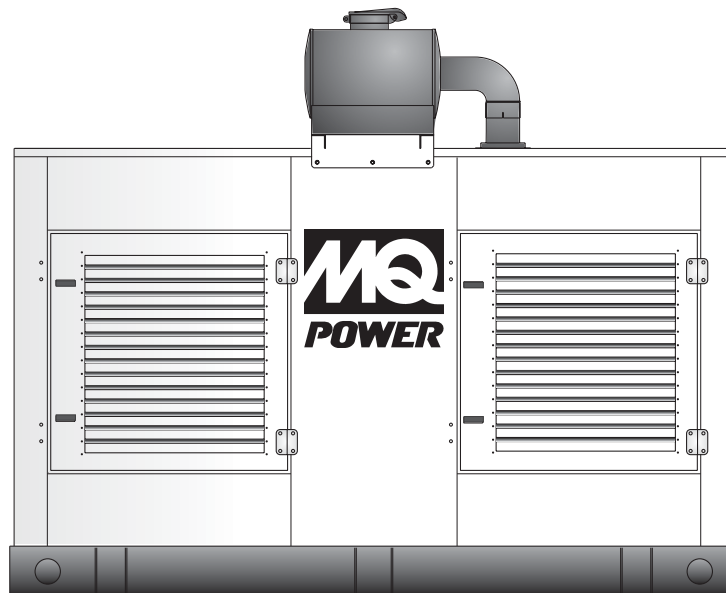

300kW Diesel On-Site Power Industrial Generator

Model	Emissions	Standby Rating	Prime Rating
MQP300IV	EPA Certified	60 Hertz	
		300kW (375 kVA)	270kW (337.5 kVA)



Standard Features

Heavy Duty Engine

- Heavy duty, 4-cycle, diesel engine; direct injection.
- Meets EPA Tier 3 emissions standards.

Alternator

- Brushless, 4-pole, synchronous, 12 lead design.
- Compliant with NEMA MG1-22, BS5000, CSA-C22-2, IEC-34-1 standards for temperature rise.
- Sustained short-circuit capability allowing downstream coordination breakers to trip without collapsing the generator field.
- Drip-proof, self-venting, amortisseur windings.
- Epoxy impregnated windings with tropical insulation for increased environmental protection and long life.
- Exceptional waveshape and voltage balance; 2/3 pitch winding to minimize harmonic distortion.

Electronic Voltage Regulator

- Encapsulated electronic voltage regulator precisely regulates the current into the exciter field.
- Solid-state, voltage regulation of $\pm 1.0\%$ no load to full load.

Full Load Acceptance

- Accepts 100% of standby nameplate rating in one step, in compliance with NFPA, para 5-13.2.6.

Cooling System

- Closed circuit, pressurized system with ambient temperature rating of 50°C (122°F).

Generator Control Panel

- MEC 20™ microprocessor-based, digital control panel; vibration isolated and NFPA110 compliant.
- Liquid crystal display screen with alphanumeric readout for display and programming.
- Self-diagnostic feature continuously verifies processing, memory circuits and input/output.

Skid and Housing

- Generator available as skid-mount or sub-base tank mount design.
- Integral vibration isolators.
- Outdoor weather-protective housing or sound-attenuated housing designs.

Warranty

- Engine-generator sets are covered by an express written 2-year limited warranty.
- Optional extended warranties available.



300kW Diesel On-Site Power Industrial Generator

Alternator Specifications	
Manufacturer/Model	Marathon Magna Plus, 432CSL6212
Type	4-Pole, Rotating Field
Exciter Type	Brushless, PMG
Number of Leads	12 Lead, Reconnectable
Voltage Regulator	SE350, Solid State, Volts per Hertz
Insulation	NEMA MG1-1.66
Material	Class H
Temperature Rise	125°C, Standby Rating
Bearing, Type	Single, Sealed
Coupling	Flexible Disk Type
Cooling Air Volume	1020 cfm
Amortisseur Windings	Full
Voltage Regulation (no load to full load)	±1%
Single Step Load Acceptance per NFPA 110	100% of Rating

Engine Specifications

Manufacturer/Model	Iveco Motors / Cursor10 TE1X *
Type	4-cycle, direct injection, turbocharged, aftercooled
Cylinder Arrangement	6 in line
Displacement	628.5 in ³ (10.3 liter)
Bore	4.92 in. (125 mm)
Stroke	5.51 in. (140 mm)
Compression Ratio	16.5 : 1
Cylinder Block	Cast iron
Cylinder Head	Cast iron
Crankshaft	Forged steel
Brake Mean Effective Pressure (BMEP)	314.7 psi (2170 kPa)
Rated RPM	1800 RPM
Max. Power @ Rated RPM (with fan)	417 hp (311 kW)
Governor Type	Electronic
Frequency Regulation: no load to full load	Isochronous under varying loads from no load to 100% rated load
Frequency Regulation: Steady State	±0.25 of mean value for constant loads from no load to full load
Air Cleaner Type	Dry

* EPA engine model number F3AE9685

Rating Guidelines

STANDBY POWER: Rating corresponds to ISO Standard Fuel Stop Power. It is applicable for supplying standby electrical power at variable load in areas with well established electrical networks in the event of normal utility power failure. No overload capability is available for this rating.

PRIME POWER: Rating corresponds to ISO Standard Power for continuous operation. It is applicable for supplying electrical power at variable load for an unlimited number of hours instead of commercially purchased power. A 10% overload capability is available for this rating.

SINGLE PHASE OUTPUT: Broad range alternators supply single phase output up to 2/3 set rated 3-phase kW at 1.0 P.F. Refer to Amperage chart.

Amperage

Voltage	Phase	Wire	Amperage
120/208 Volt	3	4	1041
120/240 Volt	3	4	902
277/480 Volt	3	4	451

Fuel System

Fuel Injection Pump Make	Standadyne
Recommended Fuel	ASTM-D975/No.1-D & No.2-D
Fuel Filter	Spin-on, Filter/Water Separator
Maximum Fuel Flow	40.9 g/hr (155 L/hr)
Fuel Consumption	
Diesel fuel at % of Load (Standby)	gal/hr (L/hr)
100%	23.4 (88.4)
80%	17.4 (65.8)
50%	11.5 (43.6)
25%	5.7 (21.5)

Engine Electrical System

Battery Charging Alternator - Make	Bosch
Ground Type	Negative
Volts (DC)	24VDC
Ampere Rating	90A
Starter Motor Make	Denso
Starter Motor Rated Voltage	24VDC
Starter Battery Capacity	2 x 185 Ah



300kW Diesel On-Site Power Industrial Generator

Lubrication System

Type	Full pressure system
System Capacity - Less Filter	6.2 gal (23.5 L)
System Capacity - With Filter	7.9 gal (30 L)
Oil Filter	Full flow, disposable
Oil Pressure At Rated Speed	43-72 psi (300-500 kPa)
Maximum Oil Temperature	248°F (120°C)

Cooling System

Exhaust Manifold Type	Dry
Radiator Design	Horizontal Discharge
Ambient Temperature Rating	122°F (50°C)
Coolant Capacity - Engine Only	4 gal (15 L)
Coolant Capacity - with Radiator	12.7 gal (48 L)
Water Pump Design/Type	Belt driven/Centrifugal Vane
Coolant Flow	146 gal/min (552.6 L/min)
Radiator Cooling Air	344 ft³/sec (9.75 m³/sec)
Heat Rejection From Engine	1551 Btu/min (27.2 kW)
Heat Rejection To Coolant	7976 Btu/min (140kW)
Fan Diameter	27.5 in (700 mm)
Fan Horsepower	32.8 hp (24.5 kW)
High Water Temperature Indication	217°F (103°C)
Pressure Cap Setting	10.1 psi (70 kPa)

Exhaust System

Exhaust Flow at Rated kW	1964 cfm (55.6 m³/min)
Exhaust Temperature at Rated kW	926°F (497°C)
Maximum Allowable Backpressure	20 in/H ₂ O (5 kPa)
Heat Rejection To Exhaust	15465 Btu/min (271.7 kW)

Derating Factors

Derating Factors	Altitude	Ambient Temperature
The engine may be operated up to 1000m altitude and 40°C ambient temperature at the Standby rating, without derating. For operation at higher altitudes and ambient temperatures, the power should be derated according to the following factors:	<1000m=%/500m	%/5°C>40°C

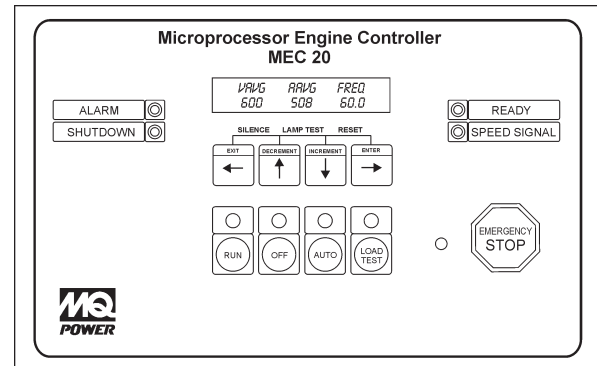

GENERATOR CONTROLLER

- MEC 20™ microprocessor-based digital generator controller.
- 12 or 24 Volt DC compatible.
- Meets all NFPA 110 requirements for emergency power systems Level I installations.
- Backlit LCD display screen with alphanumeric readout.
- Front panel keypad provides password protected programming.
- Self diagnostic features continuously verify processing, input/output and memory circuits.
- Metering accurate to ±1% within temperature range of 0°C to +50°C.
- EMI/RFI noise immunity and surge performance per IEEE C62.41.
- Certified to UL508 and CSA 22.2 #14 Industrial Control Equipment Standards.

Standard Controller Features

AC Metering Display:

- Voltage/Amperage/ Frequency
- Generator Phase Voltage / Current
- Generator Frequency

Engine Information Display:

- Engine Temperature / Oil Pressure (psi)
- Battery Voltage (DC) / Tachometer
- Hourmeter

Minor Fault Warning Display:

- Switch Not In Auto
- Low Fuel Level
- Low Oil Pressure Alarm
- Low Engine Temperature
- High Engine Temperature Alarm
- Low Battery Voltage
- High Battery Voltage
- Weak Battery Condition
- Battery Charger Input Fail
- Undervoltage
- Over / Underfrequency
- Overcurrent

Major Fault Shutdown Display:

- Overvoltage
- Emergency Stop
- Loss Of Speed
- Overcrank
- Overspeed
- Low Oil Pressure
- High Engine Temperature
- Low Coolant Level
- Spare Programmable Digital Faults

Switches And Operating Controls:

- Run / Off / Auto / Load Test Buttons
- Decrement / Increment / Previous (Exit) /Next (Enter) Program Buttons
- Emergency Stop Button
- Audible Alarm Horn – 80 dB(A) at 2 ft.
- Alarm Horn Silence Button
- Lamp Test Button
- Fault Reset Function
- RJ45 Remote Communications, External Expansion Module Ports

Timer Countdown Display:

- Engine Start Delay
- Oil Bypass
- Overcrank
- Cycle Crank
- Starter Re-engage Delay
- Bypass Delay

Control LED Indicators:

- Switch Position (Run,Off,Auto,Test)
- Common Alarm (Minor Fault)
- Common Shutdown (Major Fault)
- Generator Ready (When in Auto)
- Speed Signal
- Emergency Stop

Diagnostic LED Indicators:

- Run Output Energized
- Crank Output Energized
- Remote Start Signal Initiated
- Common Fail Output Energized
- Watchdog - CPU Running
- Programmable Output Contacts



300kW Diesel On-Site Power Industrial Generator

Generator Set Options

Alternator

- Generator Strip Heater
- Permanent Magnet Generator (PMG)

Control Panel

- Remote Monitoring and Generator Network Communications Link
- Voltage Adjusting Rheostat
- Frequency Adjust Potentiometer

Engine

- Engine Crankcase Ventilation Filter (STD)

Enclosed Unit

- Outdoor Weather-protective Housing
- Outdoor Sound-Attenuated Housing
- Critical Grade Exhaust Silencer
- Exhaust Mounting Package
- Rain Cap

Open Unit

- Critical Exhaust Silencer
- Exhaust Mounting Package

Electrical System

- Battery
- Environmental Plastic Battery Box with Lid
- Battery Charger, Equalize/Float Type 3.5 Amperes
- Battery Charger w/Alarms, Equalize/Float Type, 10 Amperes

Fuel System

- Sub-base Fuel Tank (12-hr / 285 gal), Double Wall, UL142
- Sub-base Fuel Tank (24-hr / 565 gal), Double Wall, UL142

Cooling System

- Coolant Heater
- Low Coolant Shutdown Safety
- Radiator Duct Flange

Miscellaneous

- Main Line Circuit Breaker
 - 120/208 Volt, 3 Phase, 3 Pole
 - 120/240 Volt, 3 Phase, Delta, 3 Pole
 - 139/240 Volt, 3 Phase, 3 Pole
 - 277/480 Volt, 3 Phase, 3 Pole
 - 120/240 Volt, 1 Phase, 2 Pole
- Main Line Circuit Breaker Options
 - Auxiliary Contacts
 - DC Shunt Trip
- Remote Annunciator Panel
- Remote Emergency Stop Kit
- Vibration Isolators, Spring Type
- 5-Year Extended Warranty

Automatic Transfer Switch

- Amperage _____
- No. Poles _____
- Type Enclosure _____
- Options _____

Weights and Dimensions

	A	B	C		
			Skid-mount	12hr fuel tank*	24hr fuel tank*
Open Genset	131.00 in. (3,327.4 mm)	57.00 in. (1,447.8 mm)	71.1 in. (1,807.0 mm)	85.1 in. (2,161.5 mm)	99 in. (2,514.6 mm)
	Weight		4,168 lbs (1,892 kg)	5,461 lbs (2,479 kg)	6,286 lbs (2,853 kg)
Standard Housing	131.00 in. (3,327.4 mm)	57.00 in. (1,447.8 mm)	103.6 in. (2,631.4 mm)	117.2 in. (2,976.8 mm)	131 in. (3,327.4 mm)
	Weight		5,018 lbs (2,278 kg)	6,311 lbs (2,865 kg)	7,136 lbs (3,239 kg)
Sound Intenuated Housing	166.00 in. (4,216.4 mm)	57.00 in. (1,447.8 mm)	103.6 in. (2,631.4 mm)	117.2 in. (2,976.8 mm)	131 in. (3,327.4 mm)
	Weight		5,283 lbs (2,398 kg)	6,593 lbs (2,993 kg)	7,401 lbs (2,610 kg)

* Optional

NOTE: The weights are approximate and are based on dry gensets with standard equipment. The total weight may vary according to fluid additions and/or optional equipment ordered with the unit.

Backfeed to a utility system can cause electrocution and/or property damage. Do not connect to any building's electrical system except through an approved device.

Your MQ Power dealer is:

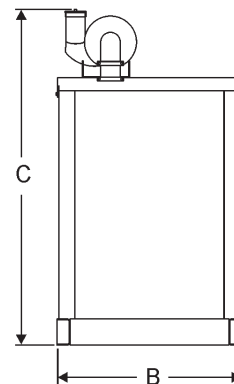
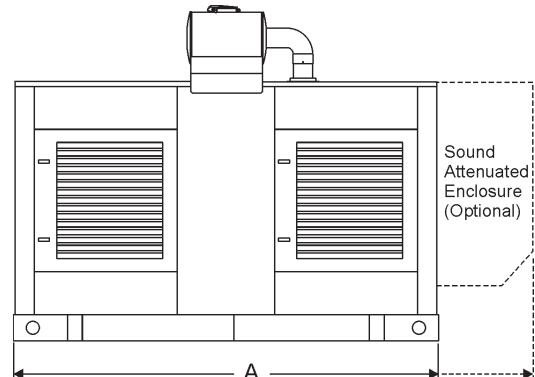

MQ POWER

POST OFFICE BOX 6254
 CARSON, CA 90749
 310-537-3700 • 800-421-1244
 FAX: 310-632-2656
 E-MAIL: mqpower@multiquip.com
 WEBSITE: www.mqpower.com