

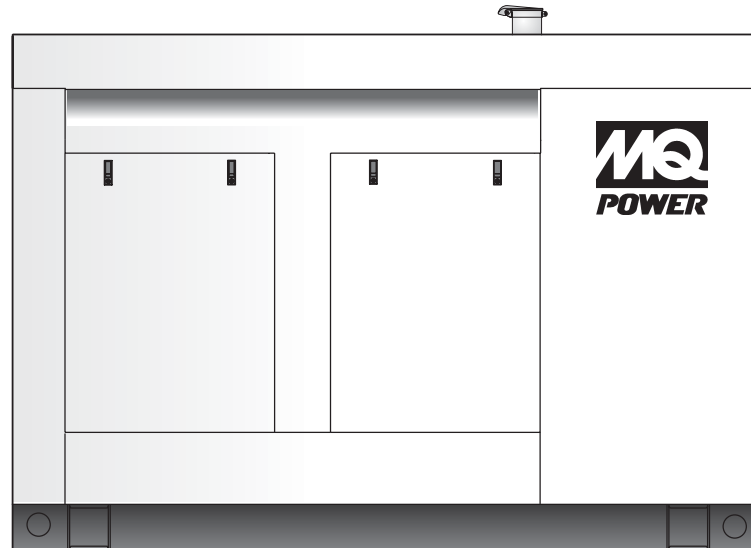

125kW Diesel On-Site Power Industrial Generator

Model	Emissions	Standby Rating	Prime Rating
MQP125IV	EPA Certified	60 Hertz	
		125kW (156.25kVA)	113kW (141kVA)



Standard Features

Heavy Duty Engine

- Heavy duty, 4-cycle, Iveco diesel engine.
- Meets EPA Tier 3 emissions standards.

Alternator

- Brushless, 4-pole, synchronous, 12 lead design.
- Compliant with NEMA MG1-22, BS5000, CSA-C22-2, IEC-34-1 standards for temperature rise.
- Sustained short-circuit capability allowing downstream coordination breakers to trip without collapsing the generator field.
- Drip-proof, self-venting, amortisseur windings.
- Epoxy impregnated windings with tropical insulation for increased environmental protection and long life.
- Exceptional waveshape and voltage balance; 2/3 pitch winding to minimize harmonic distortion.

Electronic Voltage Regulator

- Encapsulated electronic voltage regulator precisely regulates the current into the exciter field.
- Solid-state, voltage regulation of $\pm 1.0\%$ no load to full load.

Full Load Acceptance

- Accepts 100% of standby nameplate rating in one step, in compliance with NFPA, para 5-13.2.6.

Cooling System

- Closed circuit, pressurized system with ambient temperature rating of 50°C (122°F).

Generator Control Panel

- MEC 20™ microprocessor-based, digital control panel; vibration isolated and NFPA110 compliant.
- Liquid crystal display screen with alphanumeric readout for display and programming.
- Self-diagnostic feature continuously verifies processing, memory circuits and input/output.

Skid and Housing

- Generator available as skid-mount or sub-base tank mount design.
- Integral vibration isolators.
- Outdoor weather-protective housing or sound-attenuated housing designs.

Warranty

- Engine-generator sets are covered by an express written 2-year/2000 hour (whichever occurs first) limited warranty.
- Optional extended warranties available.



125kW Diesel On-Site Power Industrial Generator

Alternator Specifications	Standard 3-Phase Generator	Optional Full-Output 1-Phase Generator
Manufacturer/Model	Marathon, 363PSL1607	Marathon, 431PSL6224
Type	4-Pole, Rotating Field	4-Pole Rotating Field
Exciter Type	Brushless, Shunt Excitation	Brushless, Shunt Excitation
Number of Leads	12 Lead, Broad Range, Reconnectable	4 leads
Voltage Regulator	SE350, Solid State, Volts-per-Hertz	SE350
Insulation	NEMA MGI-1.66	NEMA MG1-1.66
Material	Class H	Class H
Temperature	125°C, Standby Rating	125°C, Standby Rating
Bearing, Type	Single, Sealed	Single, Sealed
Coupling	Flexible Disk Type	Flexible Disk type
Cooling Air Volume	700 cfm	1100 cfm
Amortisseur Windings	Full	Full
Voltage Regulation (no load to full load)	±1%	± 1%
Single Step Load Acceptance per NFPA 110	100% of Rating	100% of Rating

Engine Specifications

Manufacturer/Model	Iveco Motors / NEF67 TM1X *
Type	4-cycle, direct injection, turbocharged, aftercooled
Cylinder Arrangement	6 in line
Displacement	408 in ³ (6.7 liter)
Bore	4.09 in. (104 mm)
Stroke	5.20 in (132 mm)
Compression Ratio	17.5 : 1
Cylinder Block	Cast Iron
Cylinder Head	Cast iron, Overhead Valves
Brake Mean Effective Pressure (BMEP)	213.2 psi (1470 kPa)
Rated RPM	1800 RPM
Max. Power @ Rated RPM (with fan)	190.4 hp (142 kW)
Governor Type	Electronic
Frequency Regulation: no load to full load	Isochronous under varying loads from no load to 100% rated load
Frequency Regulation: Steady State	±0.25 of mean value for constant loads from no load to full load
Air Cleaner Type	Dry

* EPA engine model number F4GE9685A

Rating Guidelines

STANDBY POWER: Rating corresponds to ISO Standard Fuel Stop Power. It is applicable for supplying standby electrical power at variable load in areas with well established electrical networks in the event of normal utility power failure. No overload capability is available for this rating.

PRIME POWER: Rating corresponds to ISO Standard Power for continuous operation. It is applicable for supplying electrical power at variable load for an unlimited number of hours instead of commercially purchased power. A 10% overload capability is available for this rating.

SINGLE PHASE OUTPUT: Broad range alternators supply single phase output up to 2/3 set rated 3-phase kW at 1.0 P.F. Refer to Amperage chart.

Amperage

Voltage	Phase	Wire	Amperage
120/208 Volt	3	4	434
120/240 Volt	3	4	376
277/480 Volt	3	4	188
120/240 Volt	1	3	301

Fuel System

Fuel Injection Pump Make	Standadyne
Recommended Fuel	ASTM-D975/No.1-D & No.2-D
Fuel Filters	Spin-on, Filter/Water Separator
Maximum Fuel Flow	37 gal/hr (140 L/hr)
Fuel Consumption	
Diesel Fuel At % of Load	Standby gal/hr (L/hr)
100%	10 (37.8)
75%	7.4 (28.1)
50%	4.9 (18.5)
25%	2.4 (9.2)

Engine Electrical System

Battery Charging Alternator - Make	Bosch
Ground Type	Negative
Volts (DC)	12VDC
Ampere Rating	90A
Starter Motor Make/Model	Bosch
Starter Motor Rated Voltage	12VDC
Starter Battery Capacity	1 x 100 Ah



125kW Diesel On-Site Power Industrial Generator

Lubrication System

Type	Gear Driven
System Capacity - Less Filter	3.1 gal (12 L)
System Capacity - With Filter	4.5 gal (17.2 L)
Oil Filter	Full flow disposable
Oil Pressure At Rated Speed	300-500 kPa
Maximum Oil Temperature	120°C (248°F)

Cooling System

Exhaust Manifold Type	Liquid
Radiator Design	Horizontal Discharge
Ambient Temperature Rating	122°F (50°C)
Coolant Capacity - Engine Only	2.8 gal (10.5 L)
Coolant Capacity - with Radiator	7.9 gal (30 L)
Water Pump Design/Type	Belt Design, Centrifugal Vane
Coolant Flow	44.6 gal/min (169 L/min)
Radiator Cooling Air	201.9 ft ³ /sec (5.7 m ³ /sec)
Heat Rejection From Engine	1077 Btu/min (18.9 kW)
Heat Rejection To Coolant	3622 Btu/min (63.6 kW)
Fan Diameter	23.4 in. (600 mm)
Fan Horsepower	8.0 hp (6.0 kWm)
High Water Temperature Indication	217°F (103°C)
Pressure Cap Setting	10.1 psi (70 kPa)

Exhaust System

Exhaust Flow at Rated kW	1024 cfm (29 m ³ /min)
Exhaust Temperature at Rated kW	896°F (480°C)
Maximum Allowable Backpressure	20 in/H ₂ O (5 kPa)
Heat Rejection To Exhaust	7244 Btu/min (127.2 kW)

Derating Factors

	Altitude	Ambient Temperature
The engine may be operated up to 1000m altitude and 40°C ambient temperature at the Standby rating, without derating. For operation at higher altitudes and ambient temperatures, the power should be derated according to the following factors:	>1000<3000m %/500m - 3%	> 40°C %/5°C - 2%
	>3000m %/500m - 6%	

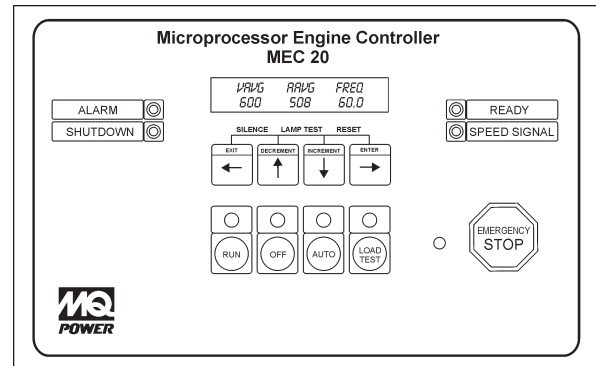

GENERATOR CONTROLLER

- MEC 20™ microprocessor-based digital generator controller.
- 12 or 24 Volt DC compatible.
- Meets all NFPA 110 requirements for emergency power systems Level I installations.
- Backlit LCD display screen with alphanumeric readout.
- Front panel keypad provides password protected programming.
- Self diagnostic features continuously verify processing, input/output and memory circuits.
- Metering accurate to ±1% within temperature range of 0°C to +50°C.
- EMI/RFI noise immunity and surge performance per IEEE C62.41.
- Certified to UL508 and CSA 22.2 #14 Industrial Control Equipment Standards.

Standard Controller Features

AC Metering Display:

- Voltage/Amperage/ Frequency
- Generator Phase Voltage / Current
- Generator Frequency

Engine Information Display:

- Engine Temperature / Oil Pressure (psi)
- Battery Voltage (DC) / Tachometer
- Hourmeter

Minor Fault Warning Display:

- Switch Not In Auto
- Low Fuel Level
- Low Oil Pressure Alarm
- Low Engine Temperature
- High Engine Temperature Alarm
- Low Battery Voltage
- High Battery Voltage
- Weak Battery Condition
- Battery Charger Input Fail
- Undervoltage
- Over / Underfrequency
- Overcurrent

Major Fault Shutdown Display:

- Overvoltage
- Emergency Stop
- Loss Of Speed
- Overcrank
- Overspeed
- Low Oil Pressure
- High Engine Temperature
- Low Coolant Level
- Spare Programmable Digital Faults

Switches And Operating Controls:

- Run / Off / Auto / Load Test Buttons
- Decrement / Increment / Previous (Exit) /Next (Enter) Program Buttons
- Emergency Stop Button
- Audible Alarm Horn – 80 dB(A) at 2 ft.
- Alarm Horn Silence Button
- Lamp Test Button
- Fault Reset Function
- RJ45 Remote Communications, External Expansion Module Ports

Timer Countdown Display:

- Engine Start Delay
- Oil Bypass
- Overcrank
- Cycle Crank
- Starter Re-engage Delay
- Bypass Delay

Control LED Indicators:

- Switch Position (Run,Off,Auto,Test)
- Common Alarm (Minor Fault)
- Common Shutdown (Major Fault)
- Generator Ready (When in Auto)
- Speed Signal
- Emergency Stop

Diagnostic LED Indicators:

- Run Output Energized
- Crank Output Energized
- Remote Start Signal Initiated
- Common Fail Output Energized
- Watchdog - CPU Running
- Programmable Output Contacts



125kW Diesel On-Site Power Industrial Generator

Generator Set Options

Alternator

- Generator Strip Heater
- Permanent Magnet Generator (PMG)

Control Panel

- Remote Monitoring and Generator Network Communications Link
- Voltage Adjusting Rheostat
- Frequency Adjust Potentiometer

Engine

- Engine Crankcase Ventilation Filter (STD)

Enclosed Unit

- Outdoor Weather-protective Housing
- Outdoor Sound-Attenuated Housing
- Critical Grade Exhaust Silencer
- Exhaust Mounting Package
- Rain Cap

Open Unit

- Critical Exhaust Silencer
- Exhaust Mounting Package

Electrical System

- Battery
- Environmental Plastic Battery Box with Lid
- Battery Charger, Equalize/Float Type 3.5 Amperes
- Battery Charger w/Alarms, Equalize/Float Type, 10 Amperes

Fuel System

- Sub-base Fuel Tank (12-hr / 125 gal), Double Wall, UL142
- Sub-base Fuel Tank (24-hr / 250 gal), Double Wall, UL142

Cooling System

- Coolant Heater
- Low Coolant Shutdown Safety
- Radiator Duct Flange

Miscellaneous

- Main Line Circuit Breaker
 - 120/208 Volt, 3 Phase, 3 Pole
 - 120/240 Volt, 3 Phase, Delta, 3 Pole
 - 139/240 Volt, 3 Phase, 3 Pole
 - 277/480 Volt, 3 Phase, 3 Pole
 - 120/240 Volt, 1 Phase, 2 Pole
- Main Line Circuit Breaker Options
 - Auxiliary Contacts
 - DC Shunt Trip
- Remote Annunciator Panel
- Remote Emergency Stop Kit
- Vibration Isolators, Spring Type
- 5-Year Extended Warranty

Automatic Transfer Switch

- Amperage _____
- No. Poles _____
- Type Enclosure _____
- Options _____

Weights and Dimensions

Housing Options	A	B	C		
			Skid-mount	12hr fuel tank*	24hr fuel tank*
Open Genset	116 in. (2,946 mm)	48 in. (1,219 mm)	56.8 in. (1,442 mm)	64.8 in. (1,646 mm)	76.8 in. (1,950 mm)
	Weight		2,660 lbs (1,207 kg)	3,175 lbs (1,428 kg)	3,475 lbs (1,577 kg)
Standard	116 in. (2,946 mm)	48 in. (1,219 mm)	69.0 in. (1,752 mm)	77.0 in. (1,955 mm)	89 in. (2,260 mm)
	Weight		3,295 lbs (1,495 kg)	3,810 lbs (1,729 kg)	4,110 lbs (1,865 kg)
Sound Attenuated	116 in. (2,946 mm)	48 in. (1,219 mm)	69.0 in. (1,752 mm)	77.0 in. (1,955 mm)	89 in. (2,260 mm)
	Weight		3,350 lbs (1,520 kg)	3,865 lbs (1,754 kg)	4,165 lbs (1,890 kg)

* Optional

NOTE: Weights are approximate and based on dry gensets with standard equipment. The total weight may vary according to fluid additions and/or optional equipment ordered with the unit.

Backfeed to a utility system can cause electrocution and/or property damage. Do not connect to any building's electrical system except through an approved device.

Your MQ Power dealer is:

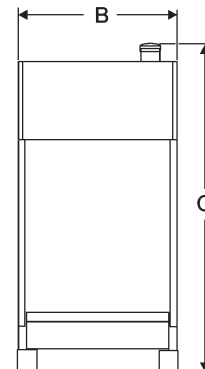
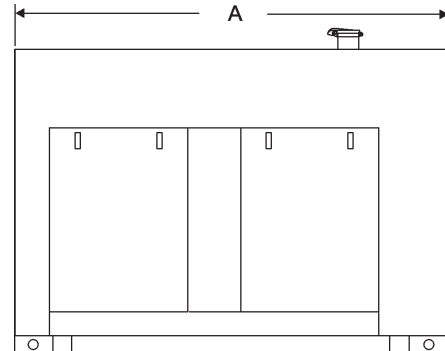

MQ POWER

POST OFFICE BOX 6254
 CARSON, CA 90749
 310-537-3700 • 800-421-1244
 FAX: 310-632-2656
 E-MAIL: mqpower@multiquip.com
 WEBSITE: www.mqpower.com