

Installation Drawings

Front End View

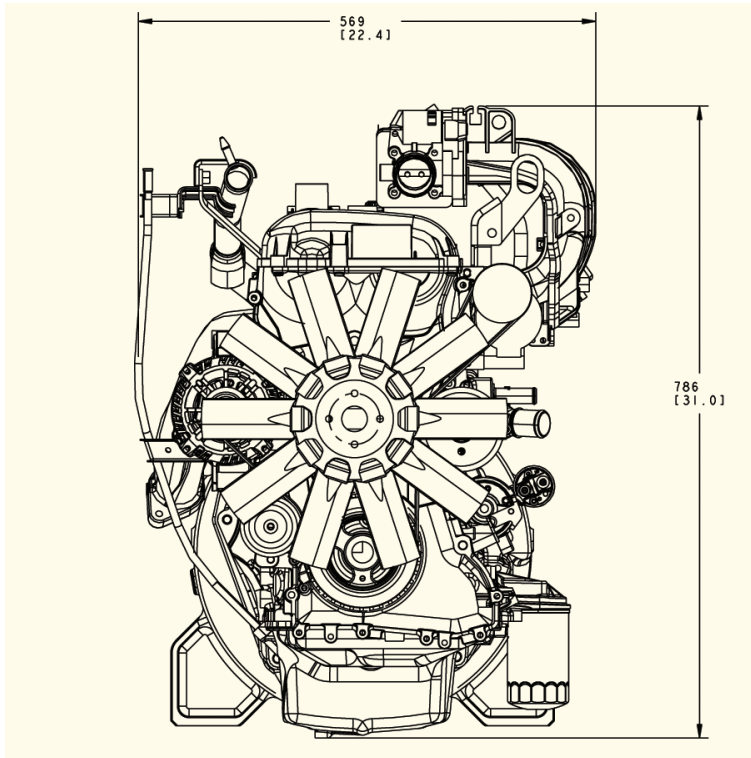

Left Side View

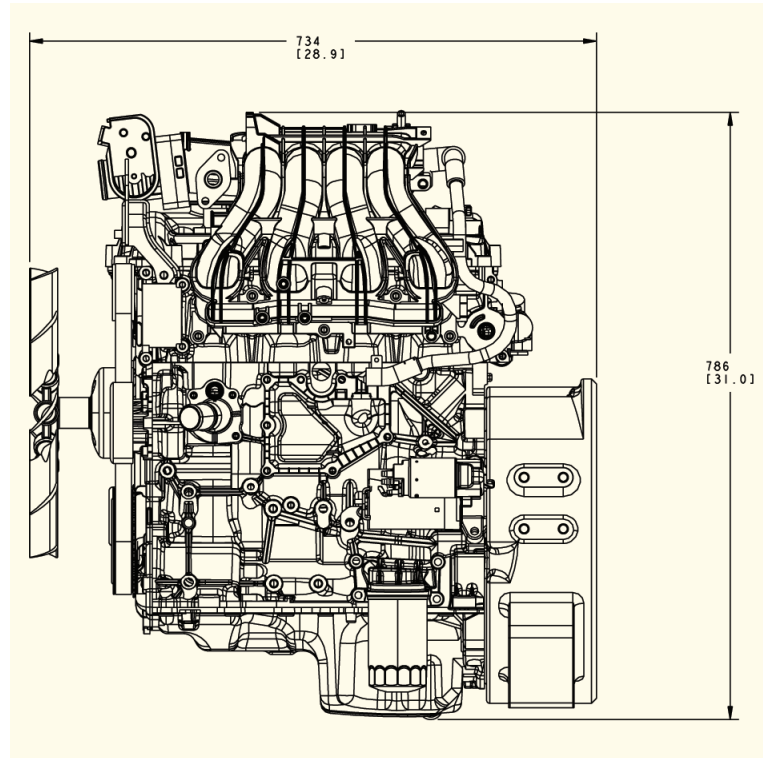

Power Curves (corrected per SAE J1995)

Gasoline

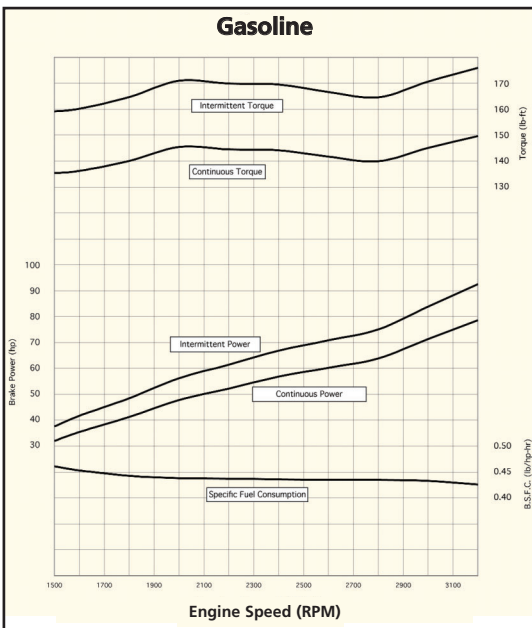

Natural Gas

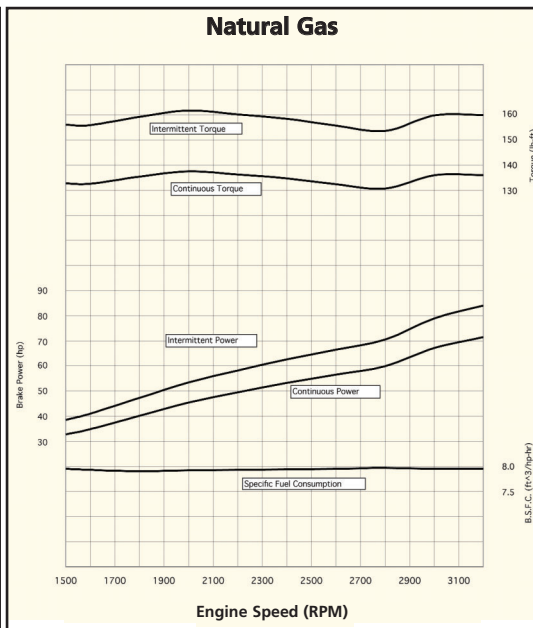

Liquefied Petroleum Gas

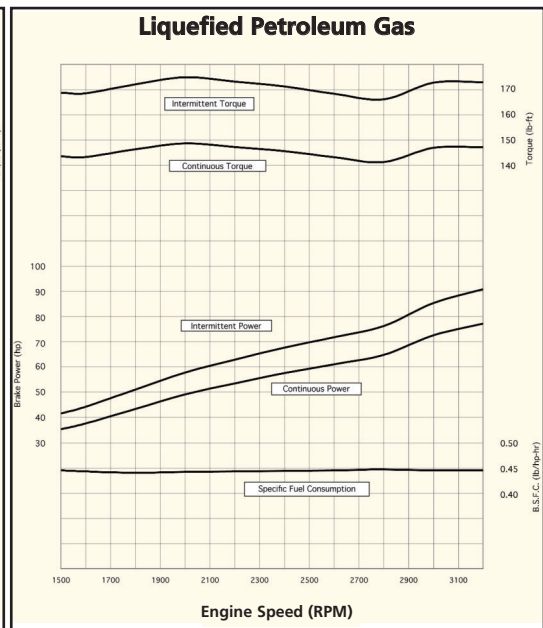

Powertech Engines, Inc.
 (800) 784-1776
www.powertechengines.com



DSG-423^{EFI}

2.3-Litre 4-Cylinder



Options

Engine Cooling Fans

- 15" (381mm) diameter suction
- 15" (381mm) diameter pusher

Flywheels

- 10" (254mm) SAE over-center clutch
- flat face flywheel

Flywheel Housings

- SAE #4

Exhaust Manifold

- rear dump down

Power Steering Pump

Wiring Harnesses

Discrete Speed Switch

Variable Speed Hand Throttle

Variable Speed Foot Pedal

Engine Mounts

- Automotive with insulators
- Open power unit

Electronic Instrument Panel, Gauges

Three Way Catalyst / Muffler

Transmissions

5R55E electronic shift

Emissions Information

California Air Resources Board (CARB)
Environmental Protection Agency (EPA)
Emission Certified Packages Available.

Warranty

Contact Engine Distributors, Inc
for warranty details.



Powertrain Assemblies
& Components
Provided By Ford
Component Sales

Specifications

Engine Type	I-4
Bore and Stroke	3.44" x 3.7" (87mm x 94mm)
Displacement	2.3 Litre (140 CID)
Compression Ratio	9.7:1
Oil Capacity.....	4 qts. including filter
Net Weight	290 Lbs. with accessories (132 Kgs.)
Dimensions	L 23" x W 22.4" x H 31" (584 mm x 569 mm x 787 mm)

Gasoline (corrected per SAE J1995)

Fuel Specification	87 A.K.I.
Intermittent Gross Power	93 HP @ 3200 RPM (69 kW @ 3200 RPM)
Continuous Gross Power	79 HP @ 3200 RPM (59 kW @ 3200 RPM)
Intermittent Gross Torque	156 Ft. Lbs. @ 3200 RPM (208 Nm @ 3200 RPM)
Continuous Gross Torque	130 Ft. Lbs. @ 3200 RPM (174 Nm @ 3200 RPM)

Natural Gas (corrected per SAE J1995)

Fuel Specification	1050 BTU/FT3
Intermittent Gross Power	84 HP @ 3200 RPM (63 kW @ 3200 RPM)
Continuous Gross Power	72 HP @ 3200 RPM (54 kW @ 3200 RPM)
Intermittent Gross Torque	140 Ft. Lbs. @ 3200 RPM (189 Nm @ 3200 RPM)
Continuous Gross Torque	116 Ft. Lbs. @ 3200 RPM (157 Nm @ 3200 RPM)

Liquefied Petroleum Gas (corrected per SAE J1995)

Fuel Specification	HD-5
Intermittent Gross Power	91 HP @ 3200 RPM (68 kW @ 3200 RPM)
Continuous Gross Power	77 HP @ 3200 RPM (57 kW @ 3200 RPM)
Intermittent Gross Torque	153 Ft. Lbs. @ 3200 RPM (207 Nm @ 3200 RPM)
Continuous Gross Torque	127 Ft. Lbs. @ 3200 RPM (172 Nm @ 3200 RPM)

Standard Features / Benefits

Set-for-life valvetrain

Deep skirted, ribbed cylinder block casting for rigidity

Aluminum AA319 cylinder block cast with the Cosworth process,
including cast-in-place iron cylinder liners.

Chain driven dual camshafts with automatic tensioning system

Structural front cover and oil pan

Alternate fuel ready valvetrain components

Individual coil on plug electronic ignition

Cast aluminum camshaft cover to ensure warp-free sealing

Sintered metal connecting rods

Nodular iron crankshaft, featuring five main bearings,
eight counterweights

Broadband knock sensor, calibrated for individual cylinder use

Gasoline Sequential Port Fuel Injection

Closed loop fuel control for all fuels

Electronic engine management system with built-in engine
protection against detonation, high coolant temperature, low oil
pressure, over speed shutdown and starter lockout

Next generation governing – discrete speeds, variable speeds,
drive by wire – using the highest quality components.