

LOMBARDINI USA

"Your Partner, Not Your Competitor"

LDW 2004 CHD

Low Speed Power Unit

INTERMITTENT HP RATING @ 1800 RPM
Nb. ISO 3046 (kW/HP) =23/30.8

Low Speed Open Power Unit Includes: Base Engine, Mounted Top Tank Radiator, Radiator Fan Guard, Mounted Air Cleaner, Muffler, Muffler Guard, Pusher Fan, Fuel Filter w/ Valve, 12 Volt Electric Starter Motor, 45 Amp External Alternator, Mounting Feet, Mounted Control Panel, A-2 Regulation @ 1800 RPM, SAE 5 Housing, C 107 Flywheel

TECHNICAL SPECIFICATIONS:

NO. OF CYLS	4
BORE x STROKE (mm)	88 x 85
DISPLACEMENT (cc)	2068
OVERALL DIMS. L x W x H (mm)	828 x 577 x 921
MAX. SPEED (RPM)	1800
MIN. CONT. SPEED (RPM)	900
N. ISO 1585 (kW/HP)	24/32.2
Nb. ISO 3046 (kW/HP)	23/30.8
Na. ISO 3046 (kW/HP)	20.8/27.9
MAX TORQUE (Lb.FT/RPM)	89.9/1800
SPC. FUEL CON (g/kWh)	265
ACT. FUEL CONS (gal/h)	1.68
OIL SUMP CAPACITY (l./Qts.)	5.7/6
DRY WEIGHT (kg/lb.)	225/496

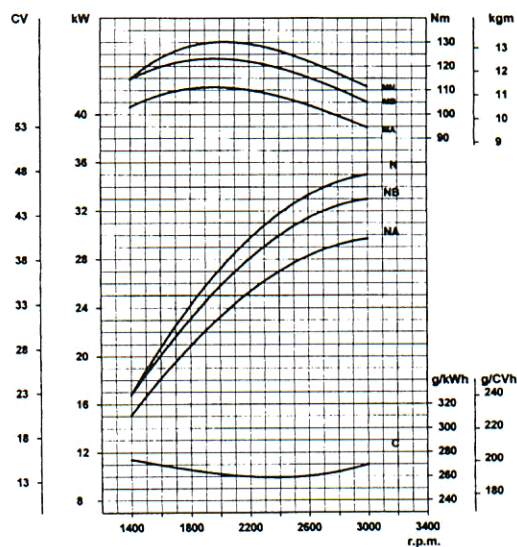

RPM

Sede di Reggio Emilia

Lombardini USA Inc.
 2150 Boggs Road, Building 300, Suite 300
 Duluth, GA 30096
 Tel: (770) 623-3554 FAX (770) 623-8833
 E-mail- lusa@lombardiniusa.com
 Internet- <http://www.lombardiniusa.com>



ISO 9001 Cert. n. 0446

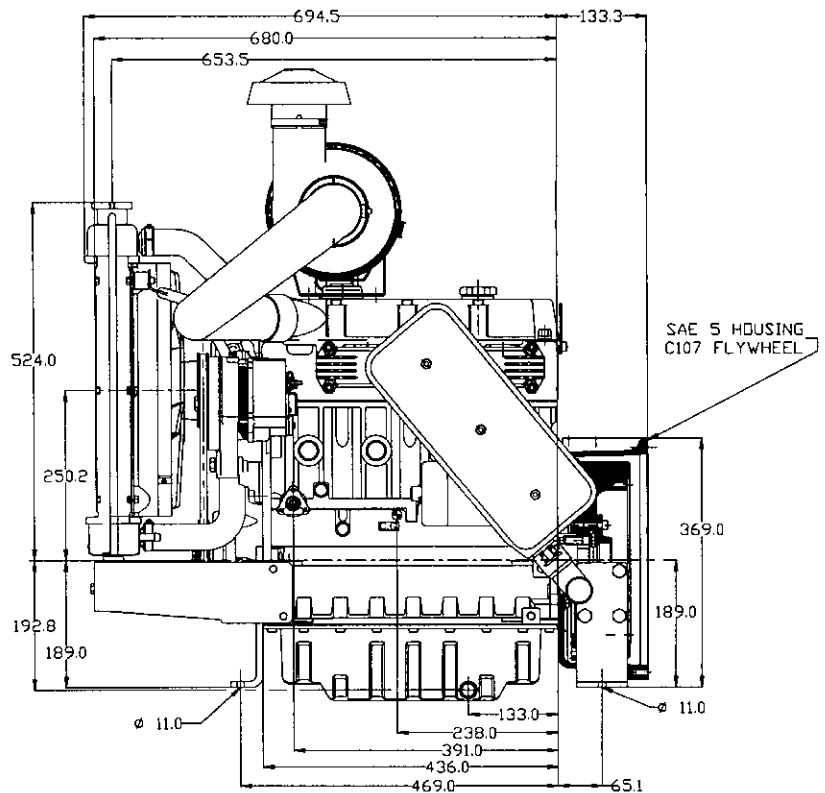
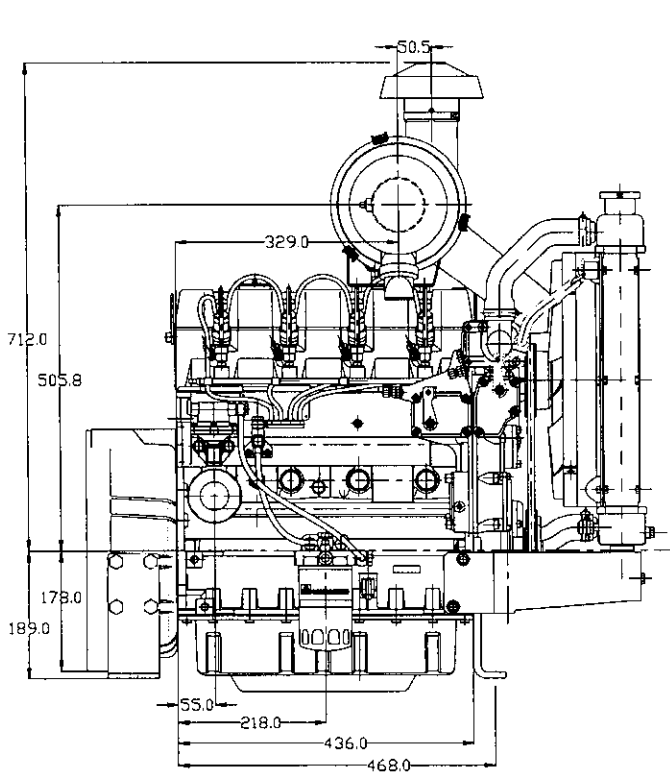

ACCESSORIES AVAILABLE:

STARTING: 12V ELECTRIC, OPTIONAL CHARGING SYSTEMS.

POWER TAKE OFF: SAE HOUSINGS & DRIVES, SHAFT EXTENSIONS, HYDRAULIC DRIVES.

AIR CLEANERS: DRY TYPE.

EXHAUST FITTINGS: VARIOUS DESIGN MUFFLERS & MANIFOLDS, MUFFLER GUARDS, LOOSE FLANGES.

SAFETY SHUTDOWN SYSTEM: FOR HIGH COOLANT TEMP AND LOW OIL PRESSURE

FUEL SYSTEM: REMOTE FUEL FILTERS, FUEL LIFT PUMP.

COOLING SYSTEM: ENGINE MOUNTED AND REMOTE RADIATORS, SUCTION AND PUSHER FANS.

MISC: MOUNTING FEET, CONTROL PANELS.

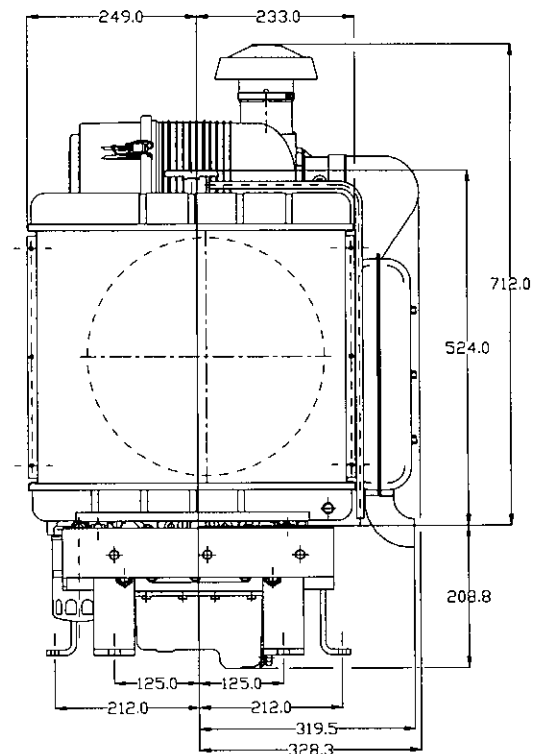

BASIC CONSTRUCTION DETAILS:

4 STROKE DIESEL, LIQUID COOLED, COUNTER CLOCKWISE ROTATION (PRIMARY PTO), INDIRECT FUEL INJECTION, PRESSURE LUBRICATION BY GEROTOR PUMP, FULL FLOW LUBE FILTER, AUTOMATIC EXTRA FUEL DEVICE FOR COLD START EASE, VARIABLE SPEED GOVERNOR, CAST IRON CRANKCASE WITH REBORABLE CYLINDERS, CAST IRON CYLINDER HEAD